



# SISTEMA TUBULAR Y DE PERFIL DE ACERO

para Flujo Continuo de Materiales



[www.siamsacv.com](http://www.siamsacv.com)

## SISTEMA TUBULAR Y DE PERFIL DE ACERO LEAN MDC









Es un sistema innovador que incrementa la productividad, flexibilidad y eliminación de desperdicios a través del diseño y desarrollo de dispositivos, ideales para la implementación de la filosofía Lean Manufacturing, para producir con excelente calidad la cantidad correcta, en el tiempo pactado y a un precio competitivo.

El **Sistema Lean MDC** fue creado para generar flujo continuo de materiales hacia las estaciones de trabajo ubicadas en las líneas de ensamble.





Las estructuras **Lean MDC** se personalizan para cada cliente de acuerdo al producto fabricado, espacio en planta y flujo de producción (longitud, ancho, alto, ergonomía, equipamiento opcional, etc.). Nuestras propuestas de solución se ajustan específicamente a las necesidades de su organización ya que todo es parametrizable o configurable. Nuestro departamento de diseño traduce el requerimiento del cliente y entrega una propuesta específica que solucione la necesidad o implemente la mejora detectada.

### ¿POR QUÉ ELEGIR ESTRUCTURAS LEAN MDC?

Las estructuras **Lean MDC** ofrecen una excelente manera para que ponga sus ideas de mejora continua (Kaizen) en acción, aplique la creatividad de su equipo de trabajo, modifique su lay-out fácilmente, redistribuya o elimine operaciones que no agregan valor a su producto.

-  Fácil ensamble, mantenimiento, limpieza y adaptación a cambios.
-  Se usa en cualquier tipo de organización, con una implementación rápida.
-  No se raya, no se despinta, ni se oxida.
-  Componentes reutilizables, no requieren soldadura.
-  Elimina desperdicios.
-  Alto retorno sobre la inversión.
-  Flexibilidad en la línea de producción.
-  Facilidad para movimientos de materiales y acceder a las piezas de producción.
-  Soluciones hechas a la medida.

### ¿QUÉ OFRECE LEAN MDC?

-  Venta de partes y estructuras
-  Instalación en piso
-  Servicio de diseño y soporte técnico
-  Experiencia, confiabilidad y seguridad

### SOLUCIONES LEAN MDC

#### SUPERMERCADOS

Se eliminan los grandes almacenes, utilizando supermercados dinámicos.

#### CARROS SURTIDORES

Facilitan el movimiento de las piezas a la línea de producción, sin la utilización del montacargas.

#### FLOWRACKS

Para que todo esté justo al alcance de la mano de los operarios, se crean con caída por gravedad.

#### MESA DE TRABAJO

Las celdas de manufactura, mesas y estaciones de trabajo se utilizan para elaborar lotes pequeños, sub ensambles o empaque.

#### AYUDAS VISUALES

Excelente herramienta para facilitarle a los operadores en forma documentada las actividades que deben realizar.

## RACKS DINÁMICOS

Elimine los grandes almacenes, utilizando los supermercados dinámicos, menos voluminosos que los almacenes tradicionales de pallets y sus grandes contenedores.

Los supermercados dinámicos, totalmente modulares y hechos a la medida, son ideales, ya que se logra más orden y una importante ganancia de espacio.

Los supermercados dinámicos se ubican a unos metros de las líneas de ensamble. Son una fase intermedia entre el almacén o proveedores y las líneas de producción.



## CARROS SURTIDORES

Hacer que las piezas lleguen a la línea de producción, sin la utilización de los montacargas, reemplazados por "los trenecitos" o carros surtidores.

Realice el movimiento de materiales más flexible, rápido, con seguridad y mucho más económico que usando los montacargas. Los trenecitos o carros surtidores solamente transportan lo que van a necesitar los operadores justo a tiempo.

Los carros surtidores de estructura ligera, se abastecen tomando las piezas de los supermercados y pueden ser empujados fácilmente por los operadores o jalados por carros de arrastre hacia las líneas de producción o ensamble.



## FLOW RACKS • RACKS DE GRAVEDAD

Perfectos para que el material esté justo al alcance de la mano de los operadores. Para reducir los movimientos inútiles en la línea de producción, se pueden implementar flow racks dinámicos con caída por gravedad. Con estos racks de gravedad se optimizan los espacios, logrando una visión completa del flujo de producción.

Permiten la liberación de espacios, por lo que ahora es posible implementar el flujo de una pieza y así poder ensamblar pequeños lotes de modelos diferentes, en la misma línea de producción.



## MESAS DE TRABAJO • CELDAS DE MANUFACTURA

Diseñadas ergonómicamente, optimizan el espacio y se adaptan al proceso productivo, fácilmente modificables para implementar mejoras. Ayudan al flujo de operaciones y materiales y reducen los movimientos innecesarios y tiempos de espera.

Ideales para diseñar células de trabajo en forma de "L" o "U" que facilitan y optimizan la producción, eliminando desperdicios.

Estas mesas pueden accessorizarse de manera que todos los elementos que participan en el proceso productivo se encuentren en su lugar y faciliten el trabajo de manufactura y que en combinación con racks de gravedad faciliten la entrada y salida de materiales de un proceso a otro.



## AYUDAS VISUALES

Son una excelente herramienta para dar a conocer información vital que debe ser desplegada en el piso de producción.

Estas ayudas visuales, son estructuras que pueden ser colocadas en las estaciones de trabajo para capacitar a los operarios en los métodos de ensamble y estándares de producción.

Con una gran versatilidad en el diseño y ajustándose a las necesidades de comunicación en la organización, las ayudas visuales se pueden utilizar en oficinas, comedor, almacén o en donde se necesite difundir información.



## COMPONENTES DEL SISTEMA



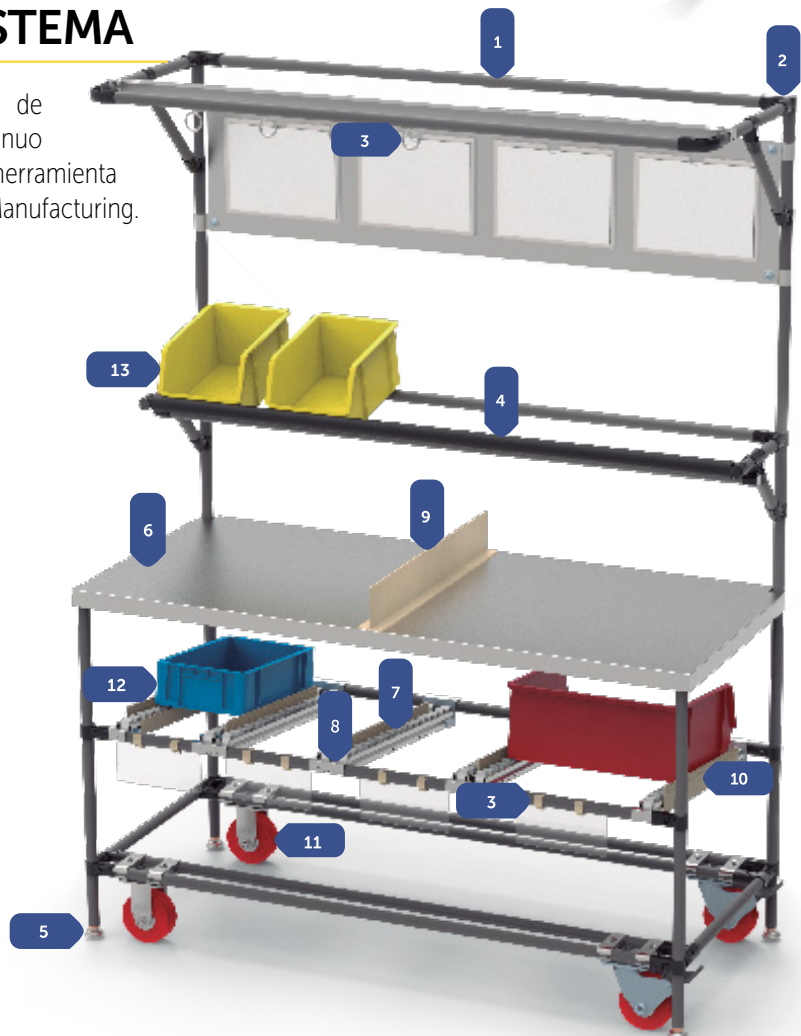

Las estructuras **Lean MDC** son un sistema de componentes diseñados para facilitar el flujo continuo de materiales a las líneas de producción, son una herramienta ideal para la implementación de la filosofía Lean Manufacturing.

- 1 • TUBOS
- 2 • UNIONES
- 3 • ACCESORIOS
- 4 • CUBIERTAS PROTECTORAS PARA TUBOS
- 5 • PATAS AJUSTADORAS
- 6 • SUPERFICIES
- 7 • ROLLERS
- 8 • MONTURAS
- 9 • ÁNGULOS
- 10 • GUÍAS
- 11 • RUEDAS
- 12 • CONTENEDORES
- 13 • GAVETAS



## TUBOS

Los tubos estándar están hechos de acero y recubiertos con resina ABS. Este recubrimiento hace que al ensamblar las uniones no se muevan ni separen.

-  Excelente durabilidad.
-  Resistencia a los impactos, solidez y ligereza.
-  Interior tratado con un recubrimiento anti-corrosivo.
-  Poco mantenimiento (limpieza con franela húmeda).

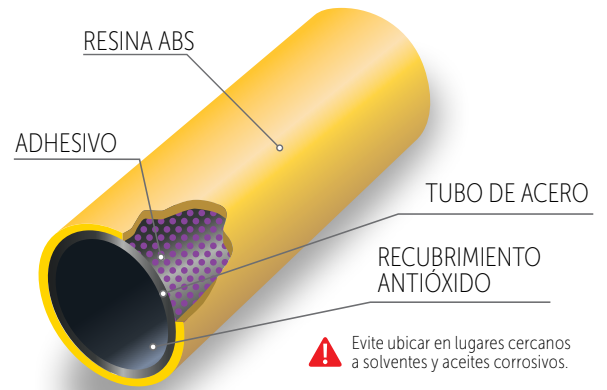

MP	-	11	-	08
Modelo		Espesor		Color



# TUBOS

TUBO	CÓDIGO	COLORES	DÍAMETRO	ESPESOR	PESO	TRAMO
ABS ESTÁNDAR	MP-1012	GRIS PROFUNDO	Ø 28 mm	0.7 mm	460 g/m	4 m
	MP-1070	IVORY				
	MP-1071	AZUL				
	MP-1072	VERDE				
	MP-1073	GRIS				
	MP-1077	BLANCO				
	MP-1100	IVORY		1.0 mm	676 g/m	
	MP-1101	VERDE				
	MP-1102	AZUL				
	MP-1103	GRIS				
	MP-1105	CAFÉ				
	MP-1106	NEGRO				
	MP-1107	BLANCO				
	MP-1108	AMARILLO				
	MP-1109	NARANJA				
	MP-1110	ROJO				
	MP-1111	ROSA				
	MP-1112	GRIS PROFUNDO				
	MP-1113	GRIS OSCURO				
	MP-1114	MORADO				
	MP-1200	IVORY		2.0 mm	1.265 g/m	
MP-1201	VERDE					
MP-1202	AZUL					
MP-1203	GRIS					
MP-1206	NEGRO					
MP-1207	BLANCO					
MP-1212	GRIS PROFUNDO					
MP-1213	GRIS OSCURO					
⚡ ANTIESTÁTICO	AP-1100	IVORY	1.0 mm			676 g/m
	AP-1110	NEGRO				
	AP-1111	GRIS				
	AP-1112	GRIS OSCURO				
⚡ CONDUCTIVO	CP-1100	NEGRO	1.0 mm	676 g/m		
⚡ ACERO INOXIDABLE	ST-1070	INOX	0.7 mm	448 g/m		
	ST-1110	INOX	1.1 mm	708 g/m		
SLIDE (CARA PLANA)	SL-1010	IVORY	1.0 mm	767 g/m		
	SL-1012	AZUL				
	SL-1013	GRIS				
⚡ ALUMINIO	AL-1102	ALUMINIO	1.1 mm	380 g/m		
SAFETY	MP-1108S	AMARILLO/NEGRO	1.0 mm	676 g/m		

⚡ ANTIESTÁTICO El tubo antiestático presenta resistencia de la superficie  $10^9\Omega \sim 10^{10}\Omega$

⚡ CONDUCTIVO El tubo conductivo presenta resistencia de la superficie  $\sim 10^5\Omega$

## UNIONES MÉTÁLICAS

Las uniones metálicas son componentes de acero que sirven para unir los tubos. Disponibles en tres acabados: pintura negra electrostática, níquel y zinc. Se ensamblan y desensamblan fácilmente utilizando tornillos M-6 y tuercas tipo T, que son ajustadas utilizando una llave Allen de 5mm, conectando con facilidad y exactitud los tubos para armar las soluciones propuestas para el flujo continuo de materiales.

Cada unión tiene una función específica y se seleccionan de acuerdo al tipo de montaje que se requiere ensamblar.

La temperatura que pueden resistir es de -10°C a 80°C.

Todas las uniones se pueden encontrar en los siguientes acabados:



⚡ ANTIESTÁTICO  
⚡ CONDUCTIVO





<p><b>H7</b></p>  <p>180 52g</p>	<p><b>H7B</b></p>  <p>180 47g</p>	<p><b>H8</b></p>  <p>300 48g</p>	<p><b>H9</b></p>  <p>100 143g</p>
<p><b>H10</b></p>  <p>180 66g</p>	<p><b>H11</b></p>  <p>200 67g</p>	<p><b>H11B</b></p>  <p>200 67g</p>	<p><b>H12</b></p>  <p>200 63g</p>
<p><b>H13</b></p>  <p>140 97g</p>	<p><b>H14</b></p>  <p>150 81g</p>	<p><b>H15A</b></p>  <p>300 43g</p>	<p><b>H15B</b></p>  <p>300 38g</p>
<p><b>H16</b></p>  <p>300 54g</p>	<p><b>H16B</b></p>  <p>300 54g</p>	<p><b>H17</b></p>  <p>180 71g</p>	<p><b>H18</b></p>  <p>240 69g</p>
<p><b>H19</b></p>  <p>250 64g</p>	<p><b>H20</b></p>  <p>150 97g</p>	<p><b>H20S</b></p>  <p>200 64g</p>	<p><b>H21</b></p>  <p>150 104g</p>
<p><b>H45A</b></p>  <p>140 64g</p>	<p><b>H45B</b></p>  <p>140 64g</p>	<p><b>H108</b></p>  <p>140 106g</p>	<p><b>H162</b></p>  <p>180 108g</p>

# MÉTODOS DE UNIÓN

Uniones y tornillería se venden por separado

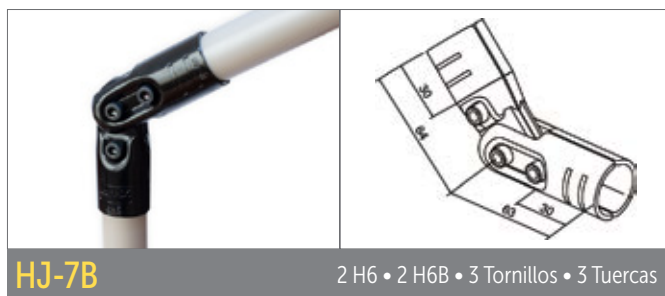
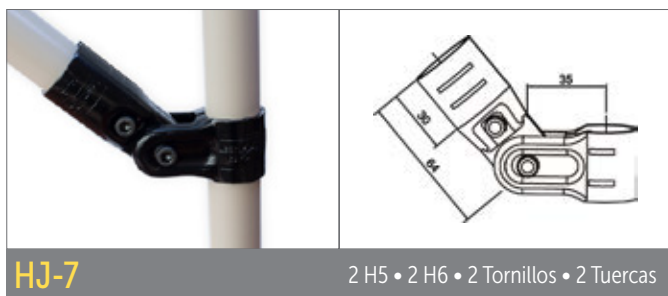
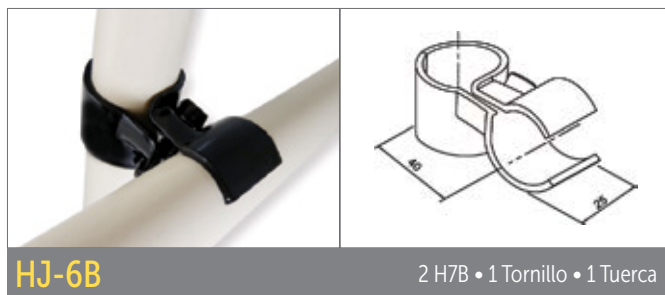
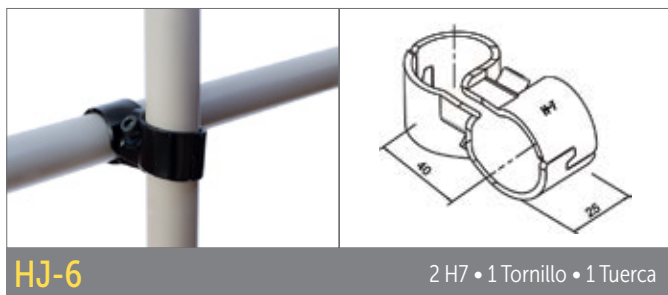
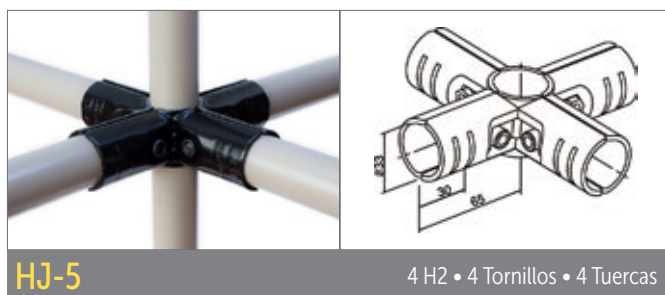
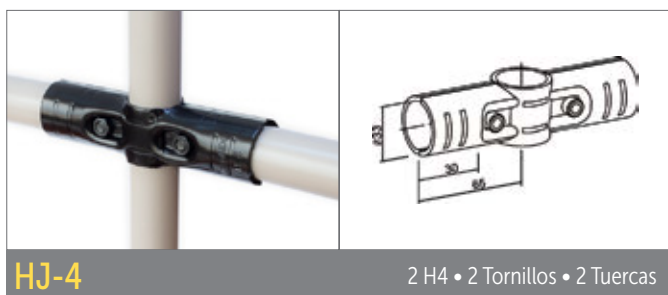
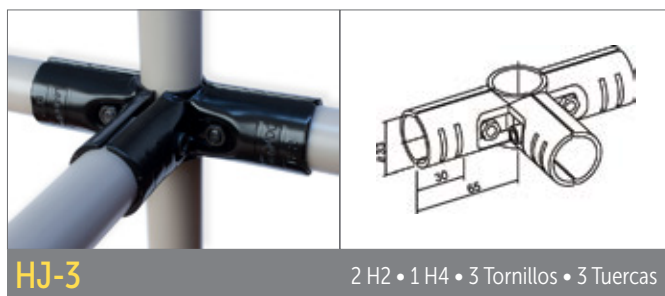
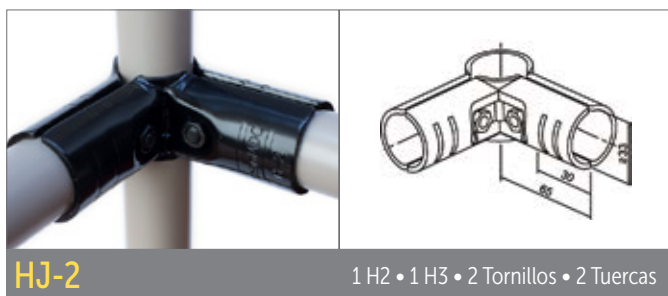
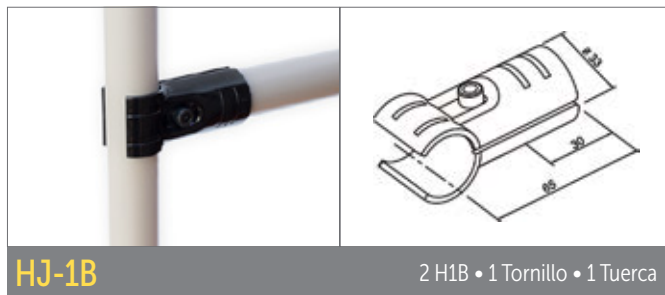
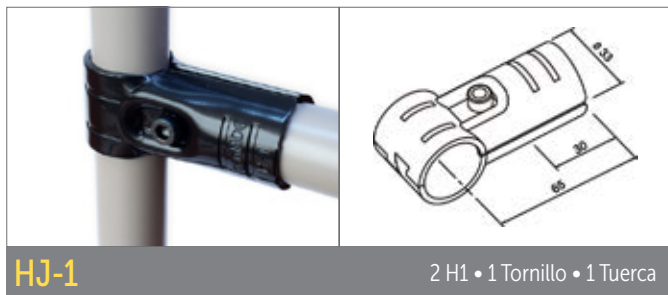

Uniones y tornillería se venden por separado

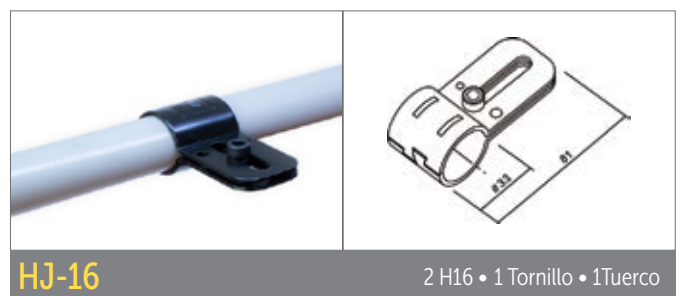
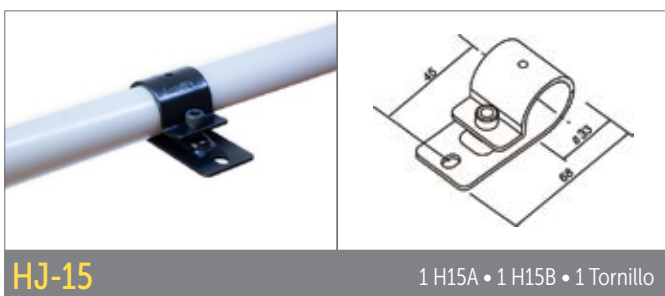
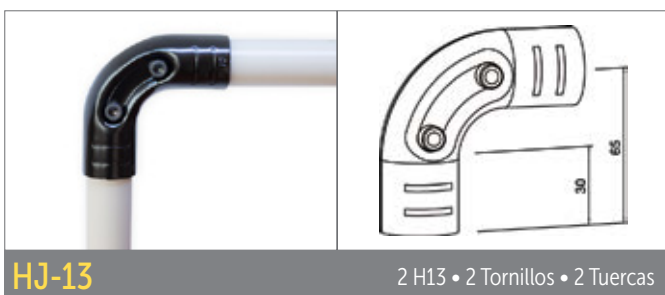
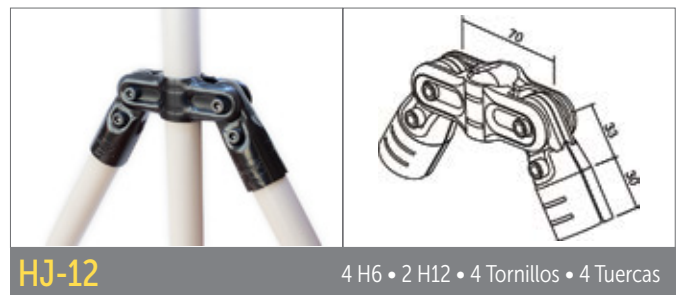
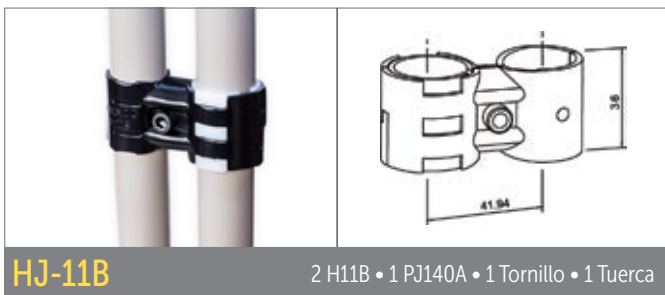
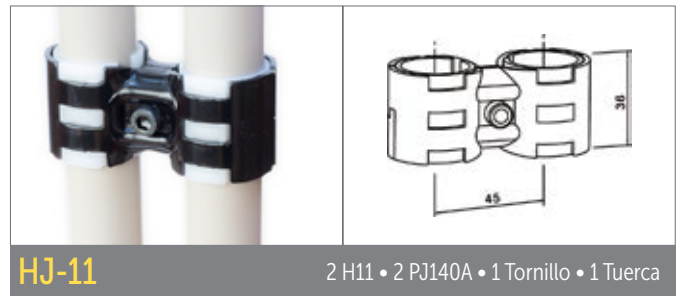
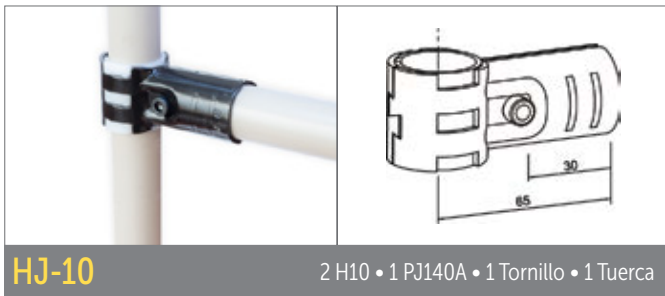
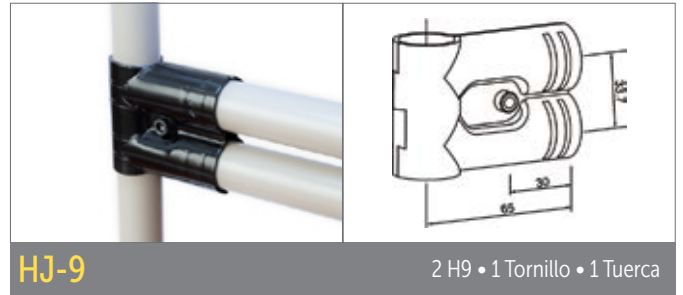
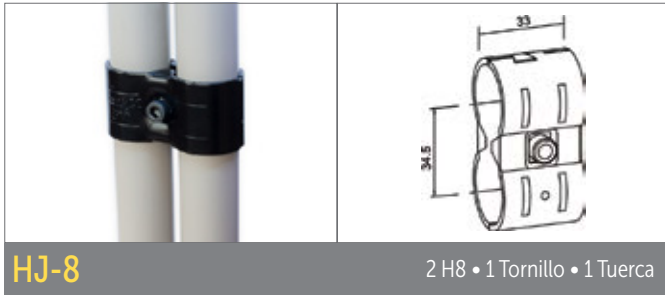

Uniones y tornillería se venden por separado

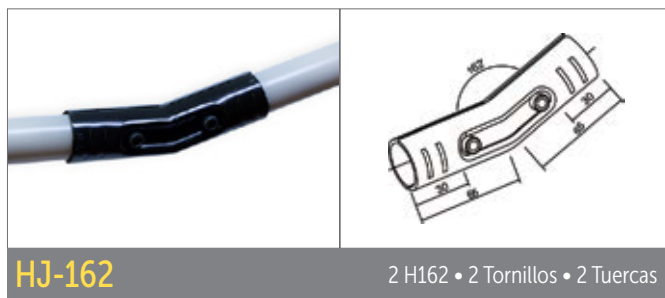
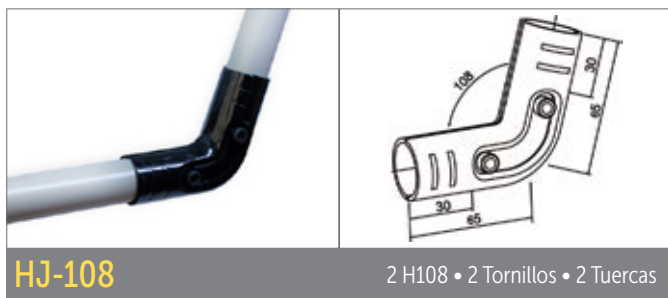
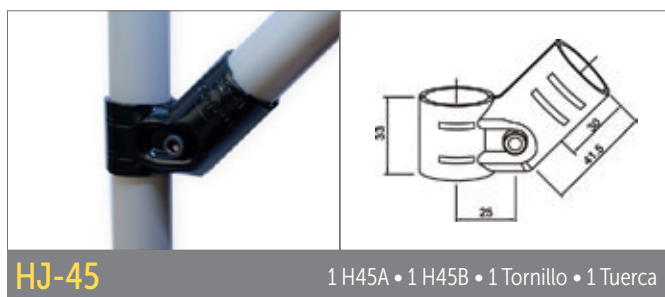
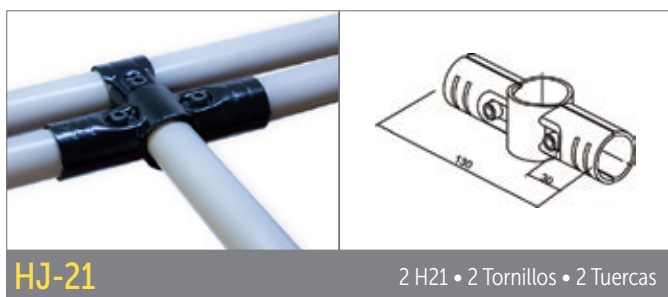
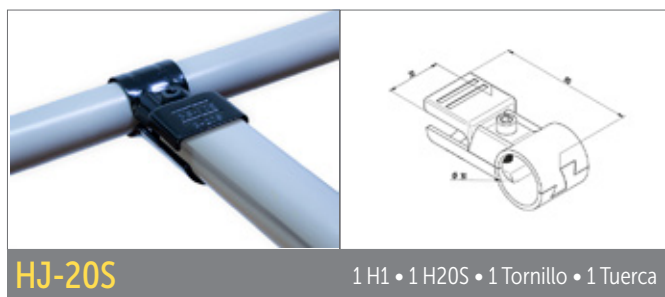
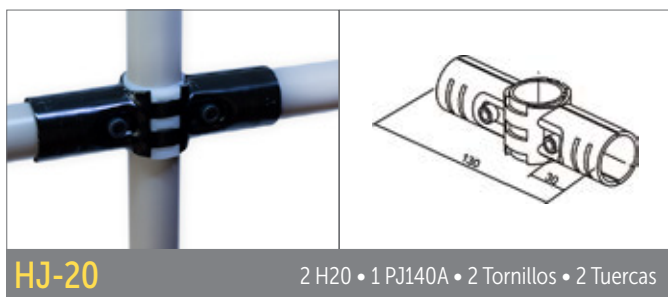
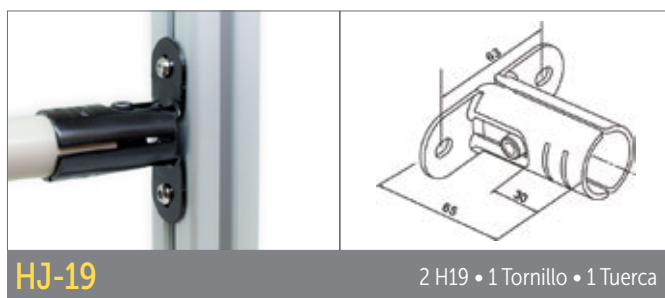
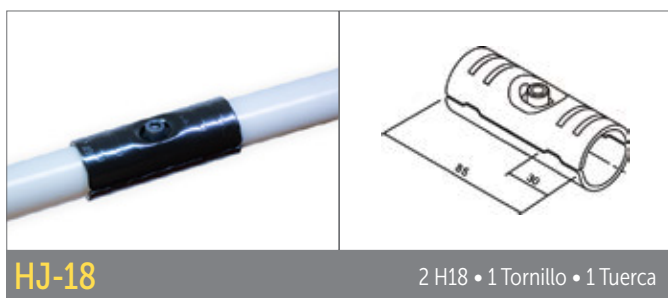
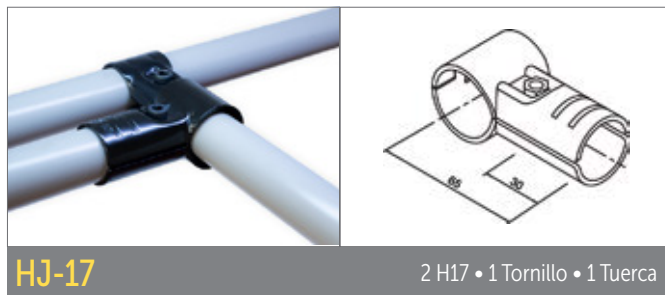
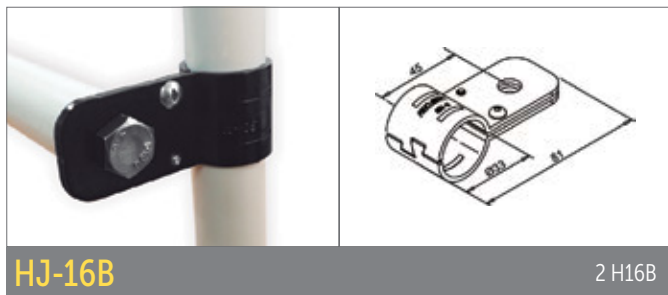

# SQR Square Racking System

El Square Racking System o Sistema Cuadrado de Acero fue desarrollado por LEAN MDC® como complemento del Sistema Tubular de Acero, con el que ahora las Estructuras Lean MDC® serán más flexibles, más resistentes, facilitarán la colocación de superficies planas y aumentarán su capacidad de carga.

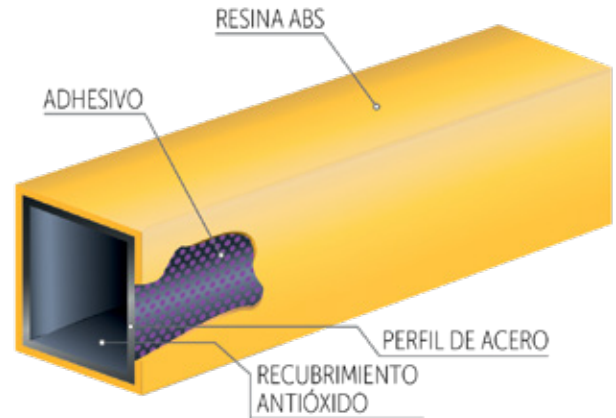

## PERFILES SQR

⚠ Evite ubicar en lugares cercanos a solventes y aceites corrosivos.

COLORES						
BLANCO	MARFIL	GRIS	AZUL	MARINO	NEGRO	INOX

**SS-1070N** INOX

ESPESOR	PESO	TRAMO
0.7 T	2.212 kg	4m

**SS-1110N** INOX

ESPESOR	PESO	TRAMO
1.1 T	3.302 kg	4m

**SQ-1107N** BLANCO

ESPESOR	PESO	TRAMO
1.0 T	3.272 kg	4m

**SQ-1100N** MARFIL

ESPESOR	PESO	TRAMO
1.0 T	3.272 kg	4m

**SQ-1102N** AZUL

ESPESOR	PESO	TRAMO
1.0 T	3.272 kg	4m

**SQ-1103N** GRIS

ESPESOR	PESO	TRAMO
1.0 T	3.272 kg	4m

Uniones y tornillería se venden por separado

**SQ-1106N** NEGRO



ESPESOR	PESO	TRAMO
1.0 T	3.272 kg	4m

**SQ-1115N** AZUL



ESPESOR	PESO	TRAMO
1.0 T	3.272 kg	4m

**SQ-1200N** MARFIL



ESPESOR	PESO	TRAMO
2.0 T	5.98 kg	4m

**SQ-1202N** AZUL



ESPESOR	PESO	TRAMO
2.0 T	5.98 kg	4m

**SQ-1203N** GRIS



ESPESOR	PESO	TRAMO
2.0 T	5.98 kg	4m

**SQ-1206N** NEGRO



ESPESOR	PESO	TRAMO
2.0 T	5.98 kg	4m

**SQ-1207N** BLANCO



ESPESOR	PESO	TRAMO
2.0 T	5.98 kg	4m

**SQ-1215N** AZUL



ESPESOR	PESO	TRAMO
2.0 T	5.98 kg	4m

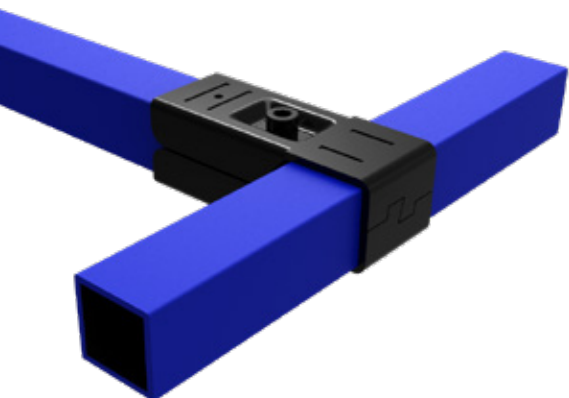

# UNIONES SQR

Las uniones se pueden encontrar en los siguientes acabados: Black • | Níquel • | Zinc • |

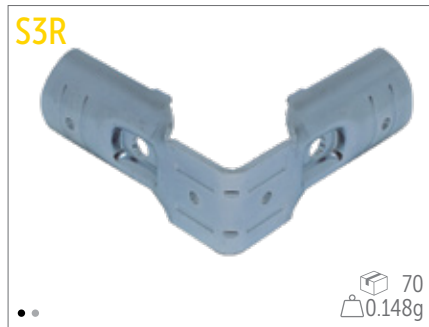
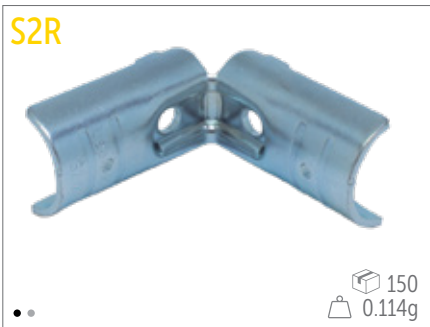

# ACCESORIOS

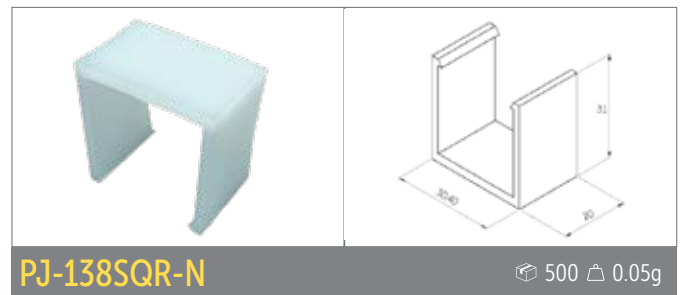
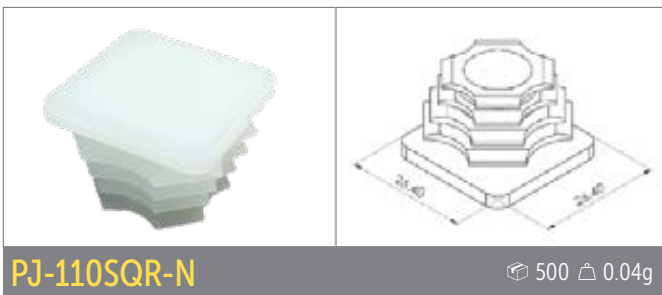

# MÉTODOS DE UNIÓN SQR

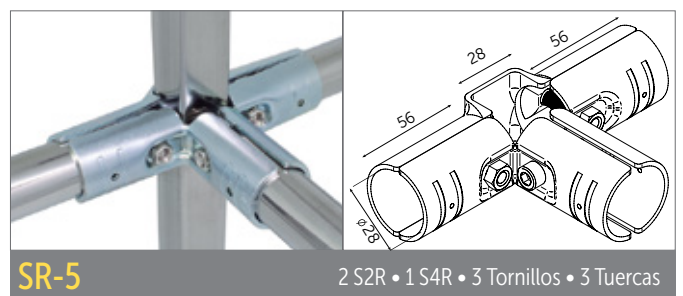
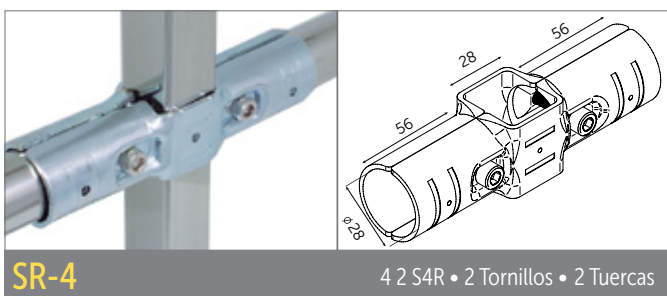
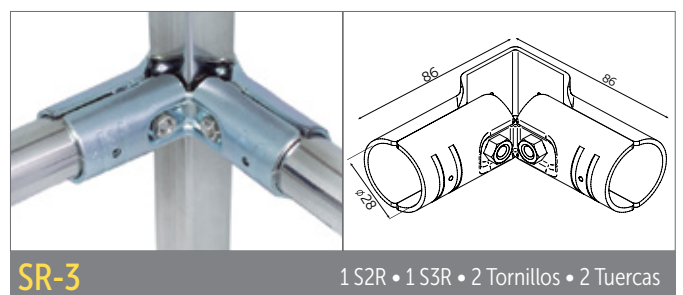
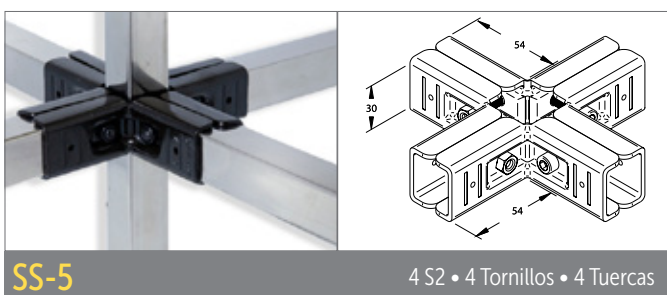
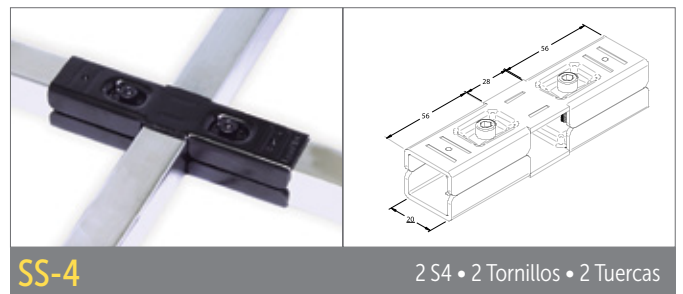
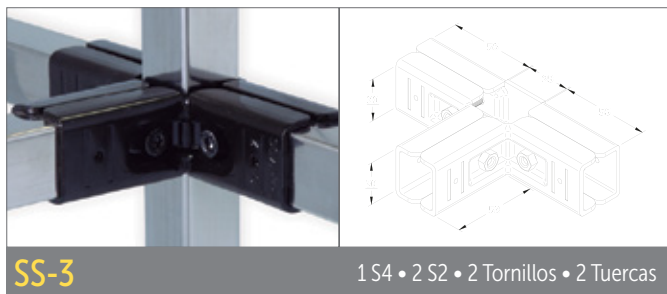
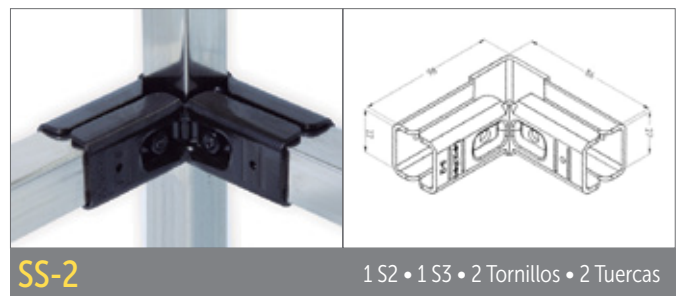
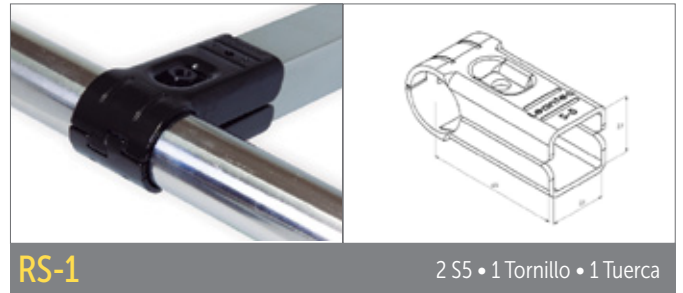
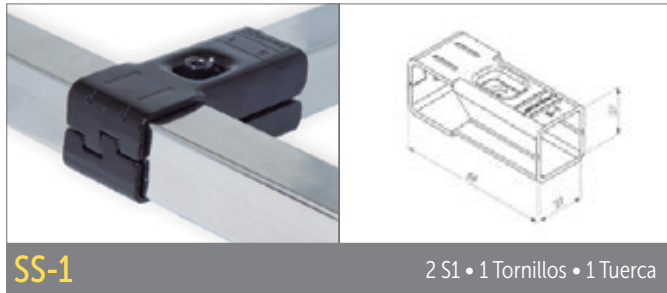



# ACCESORIOS DE PLÁSTICO

**PJ-100 R/L**

📦 200  
⚖️ 42g

**PJ-104 C**

📦 150  
⚖️ 48g

**PJ-104D**

📦 150  
⚖️ 46g

**PJ-105**

📦 220  
⚖️ 34g

Para Tubos INOX 0.7mm (ST-1070)  
INOX 1.1mm (ST-1110)

⚡ disponible en ESD

**PJ-110BK**

📦 2,500  
⚖️ 3.4g

**PJ-110ABK**

📦 2,500  
⚖️ 3.4g

**PJ-110AIV**

📦 2,500  
⚖️ 3.4g

⚡

**PJ-110AESD**

📦 2,500  
⚖️ 3.4g

**PJ-113IV**

📦 600  
⚖️ 12g

**PJ-113BIV**

📦 600  
⚖️ 21g

**PJ-118**

📦 250  
⚖️ 30g

⚡ disponible en ESD

**PJ-138BBK**

📦 1,500  
⚖️ 5.4g

**PJ-138BIV**

📦 2,000  
⚖️ 5.4g

**PJ-138C**

📦 2,000  
⚖️ 3.4g

**PJ-138SIV**

📦 2,000  
⚖️ 4.3g

⚡ ANTIESTÁTICO

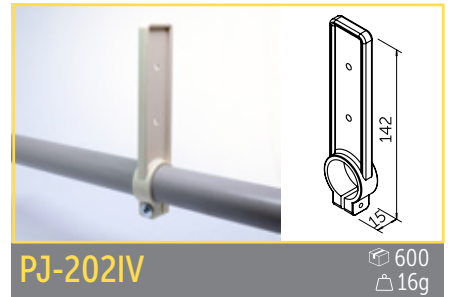
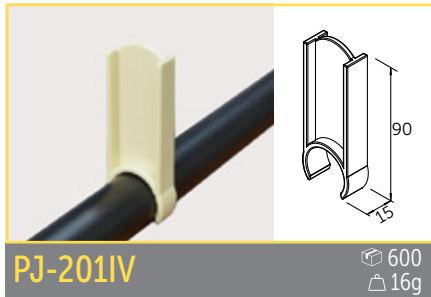
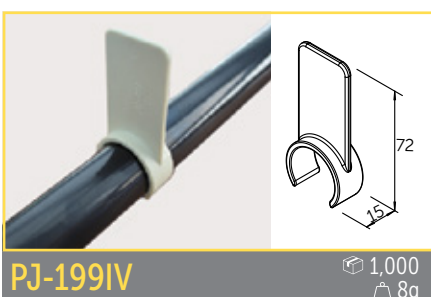
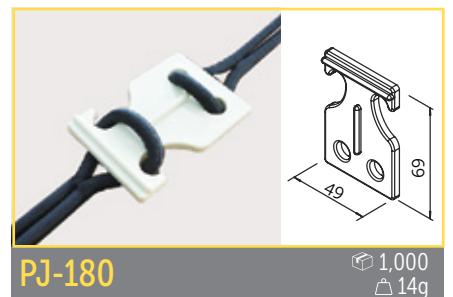
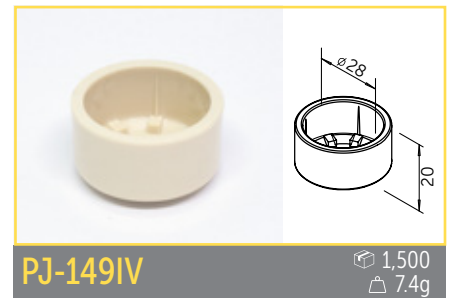
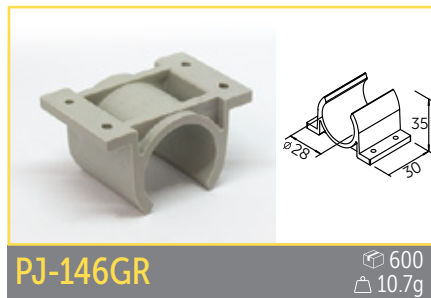
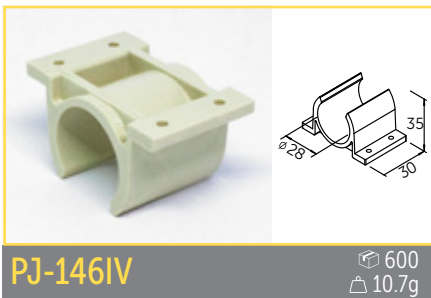
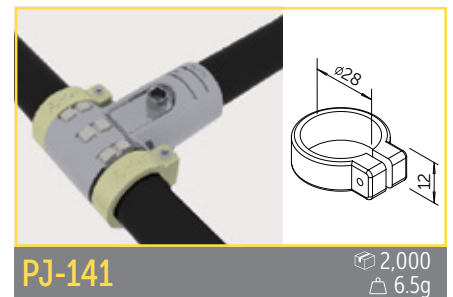
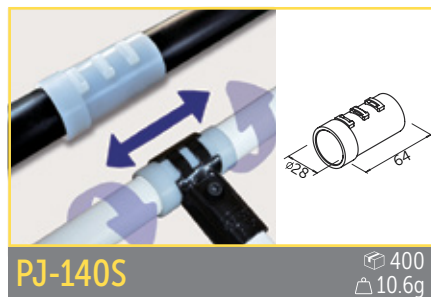
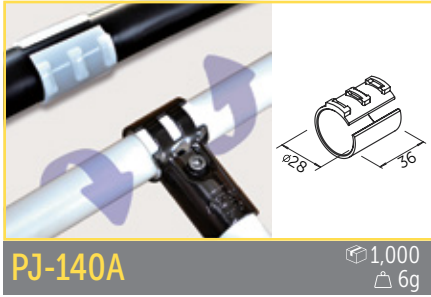

# ACCESORIOS METÁLICOS



**AT-007** 📦 50  
⚖️ 200g

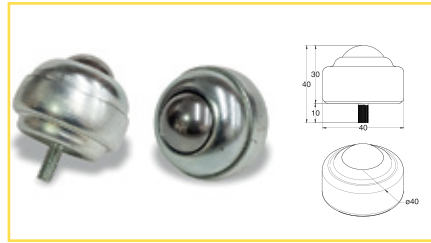

**BALLTRANSFER 1** 📦 200  
⚖️ 200g

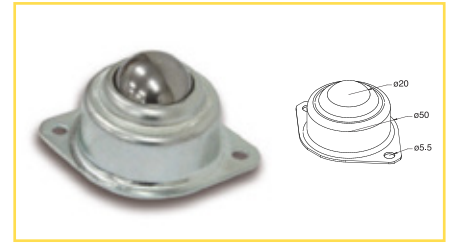

**BALLTRANSFER 12A** 📦 200  
⚖️ 170g

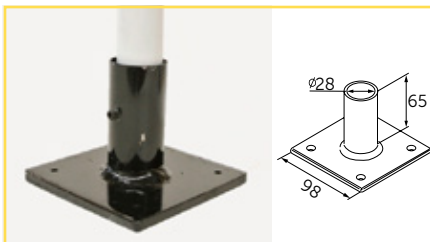

**BS-201** 📦 12  
⚖️ 612g

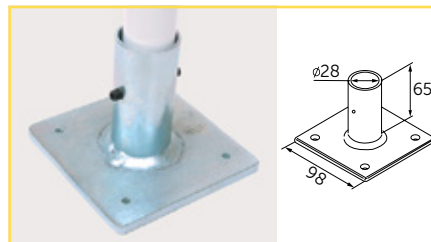

**BS-202** 📦 12  
⚖️ 606g

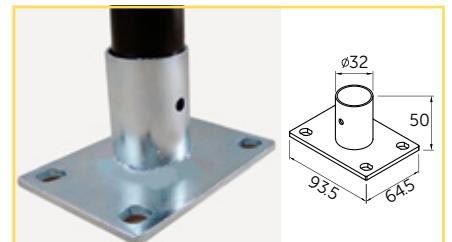

**BS-203** 📦 12  
⚖️ 606g

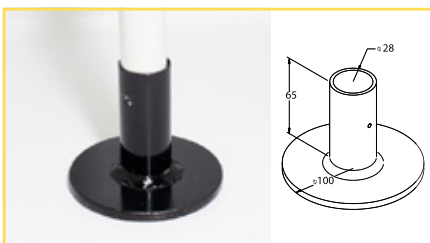

**BS-204** 📦 12  
⚖️ 612g



**H-22** 📦 80  
⚖️ 70g



**H-25** 📦 100  
⚖️ 82g



**H-26** 📦 50  
⚖️ 98g

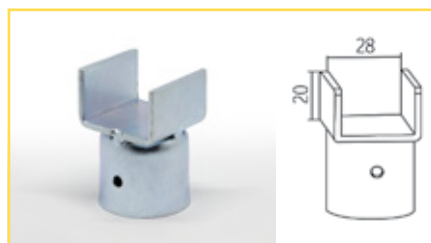

**H-28** 📦 100  
⚖️ 72g



**H-32** 📦 50  
⚖️ 35g

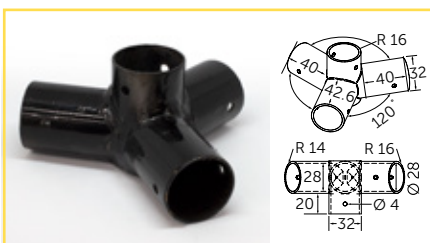

**J-33** 📦 20  
⚖️ 180g

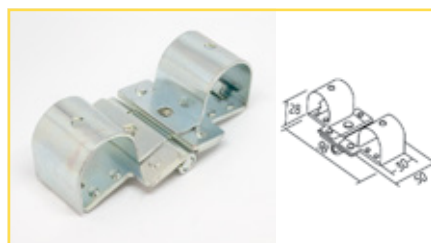

**MT-1011** 📦 100  
⚖️ 90g

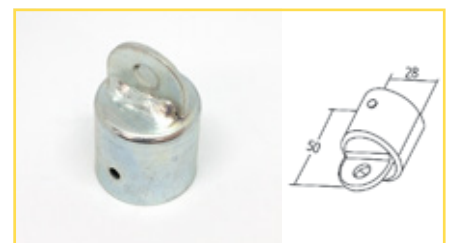

**MT1012J** 📦 100  
⚖️ 60g

**MT-1012L**

150  
 87g

**MT-1012M**

100  
 192g

**MT-1200EN**

100  
 203g

**MT-5100**

25  
 908g

**MT-5109**

150  
 106g

**MT-5109W**

120  
 120g

**MT-5110**

300  
 66g

**MT-5111**

400  
 20g

**MT-5112**

200  
 26g

**MT-5113**

150  
 62g

**MT-5114**

400  
 14g

**MT-5116**

50  
 110g

**MT-5117**

50  
 72g

**MT-5118**

30  
 176g

**MT-5119**

20  
 226g

CÓDIGO L PESO X PIEZA

ME-1009	NA	244 g
ME-1008	100	1,172 g
ME-1015	150	2,000 g
ME-1016	200	2,286 g
ME-1019	300	3,516 g

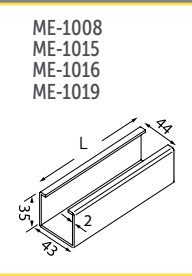
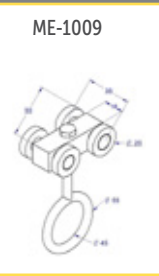

ME-1008  
ME-1015  
ME-1016  
ME-1019

**MT-5119S/M/L**

50  
400g

**MT-5119W**

35  
330g

**MT-5120**

1,000  
8g

Para Tubo 1.0 mm (MP-1100)

**MT-5123**

150  
74g

**MT-5125**

150  
48g

**MT-5126**

200  
126g

**MT-5127SV/BK**

100  
70g

**MT-5128**

100  
94g

**MT-5129**

60  
150g

**MT-5130A**

600  
22g

**MT-5130B**

600  
22g

**MT-5138 L**

20  
988g

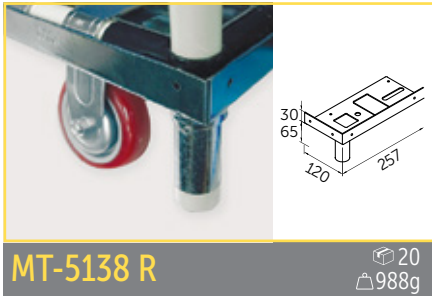

**MT-5138 R**

20  
988g

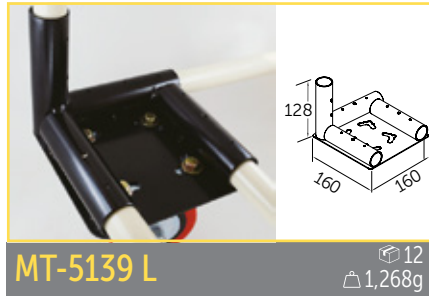

**MT-5139 L**

12  
1,268g

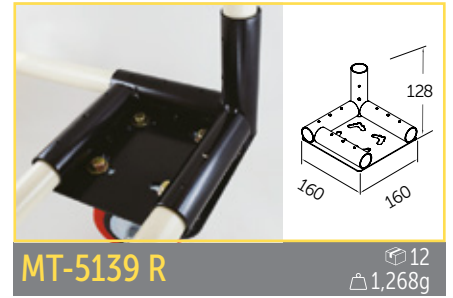

**MT-5139 R**

12  
1,268g

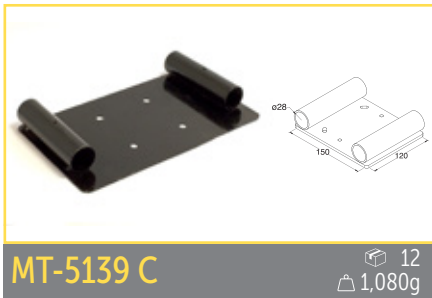

**MT-5139 C**

12  
1,080g



**MT-5142**

10  
200g



**MT-5160I**

100  
125g



Capacidad: 15, 30 y 50 kg

**MT-514315 • MT-514330 • MT-514350**  
Caja con 100 pzs • Peso x pza: 245 g

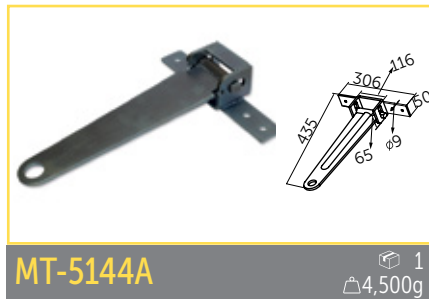

**MT-5144A**

1  
4,500g

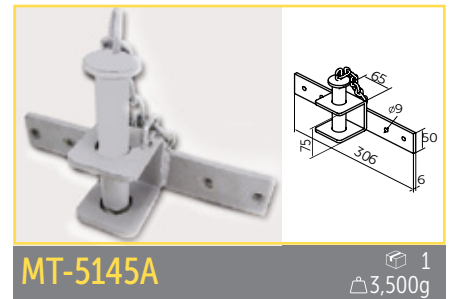

**MT-5145A**

1  
3,500g

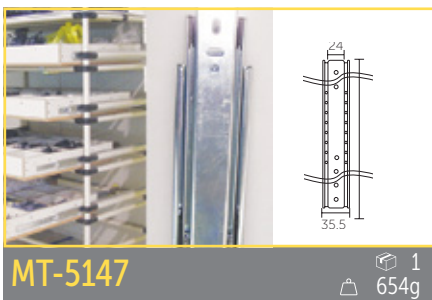

**MT-5147**

1  
654g

FRENO DE PIE	CÓDIGO	RUEDA	PESO
	MT-5148A	4" / 5"	1,206g
	MT-5148B	6"	2,802g

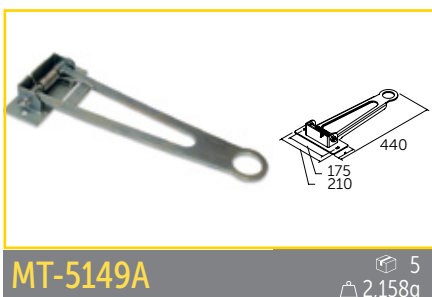

**MT-5149A**

5  
2,158g

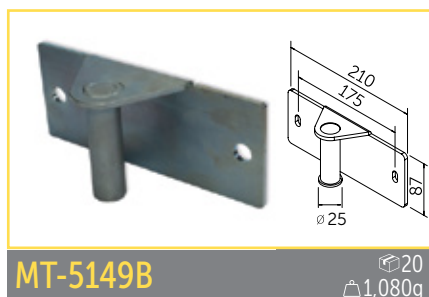

**MT-5149B**

20  
1,080g

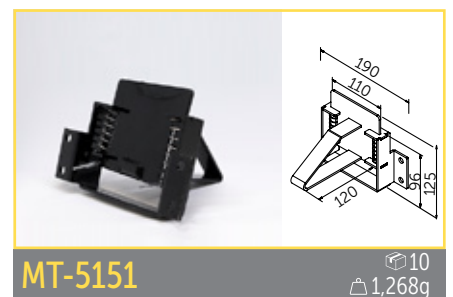

**MT-5151**

10  
1,268g

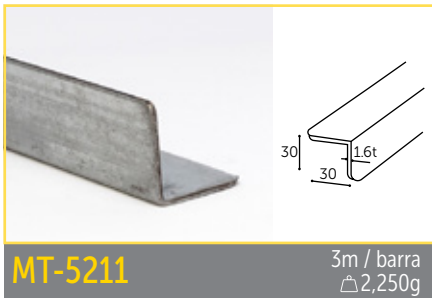

MT-5211

3m / barra  
 △2,250g

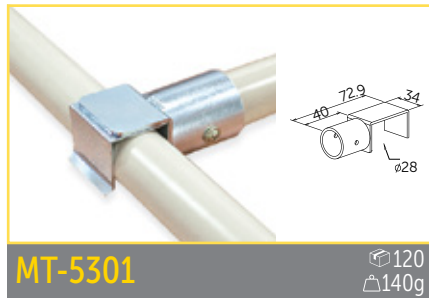

MT-5301

120  
 △140g



MT-5302

90  
 △169g

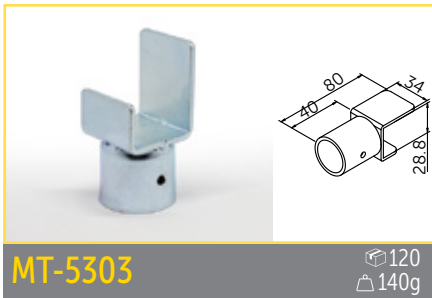

MT-5303

120  
 △140g

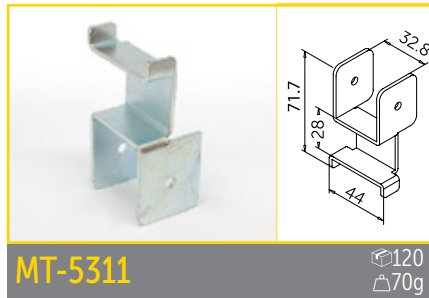

MT-5311

120  
 △70g

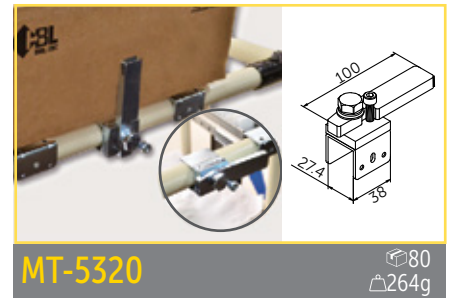

MT-5320

80  
 △264g

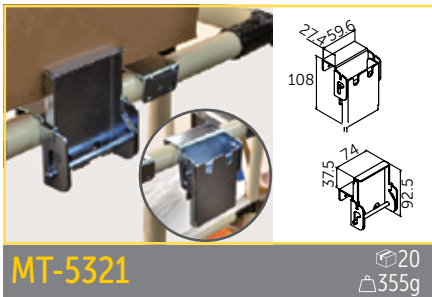

MT-5321

20  
 △355g

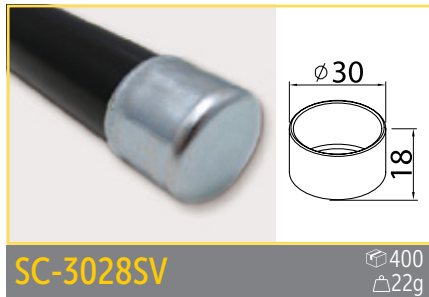

SC-3028SV

400  
 △22g



K01RD

Herramienta para  
 rebear tubos

CÓDIGO	PESO X PIEZA	A	B
WG-0230	190 g	230mm	70mm
WG-0330	240 g	330mm	
WG-0430	280 g	430mm	

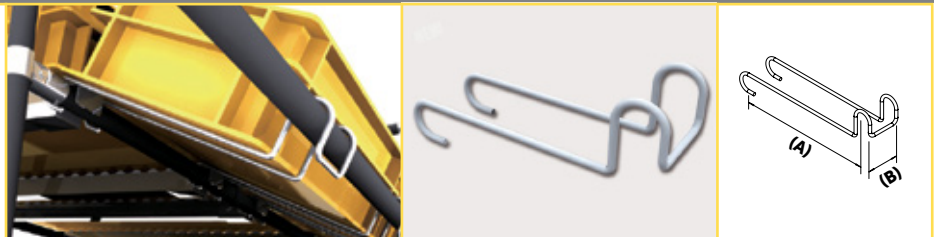

## SISTEMA DE TRACCIÓN LEAN MDC

△ 3,750g

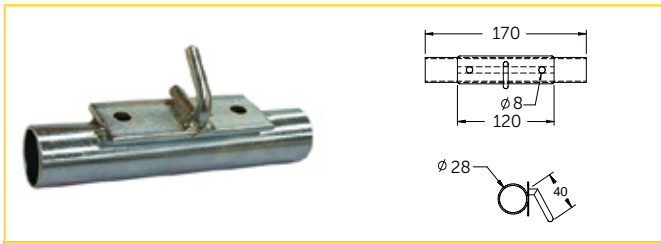
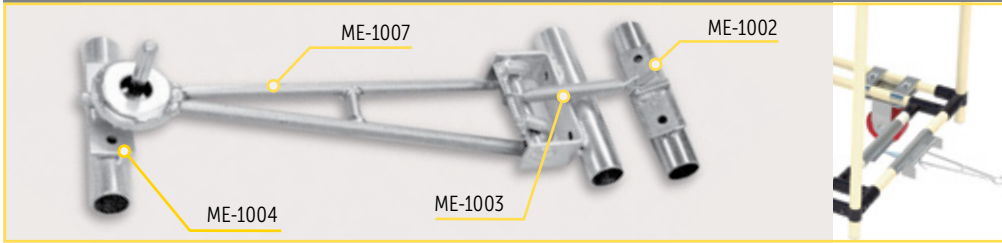

ME-1002

△ 39 g

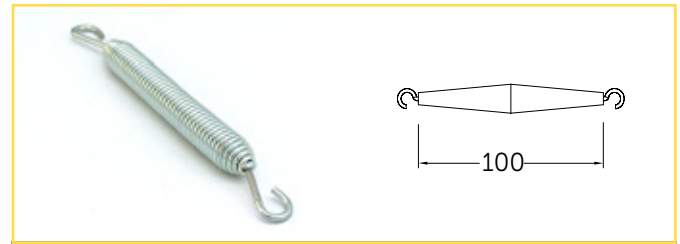

ME-1003

△ 6 g

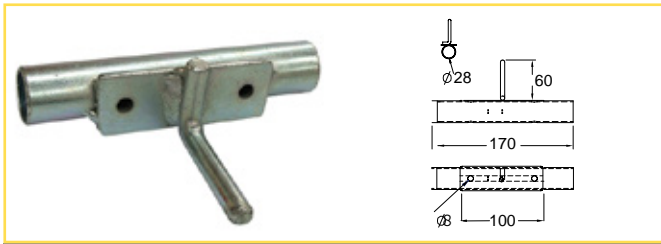

ME-1004

△ 37 g

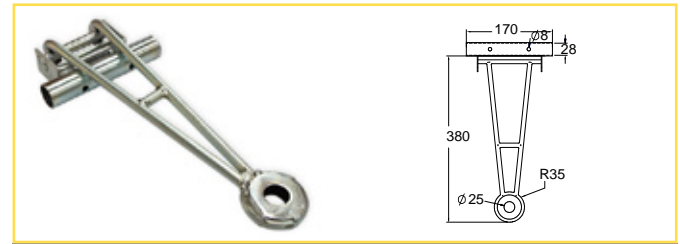

ME-1007

△ 1,710 g

## SUPERFICIES



MELAMINA



ACRÍLICO

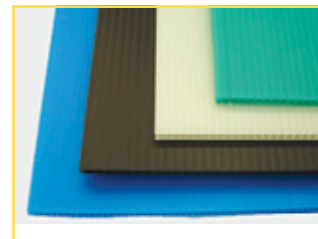

COROPLAST

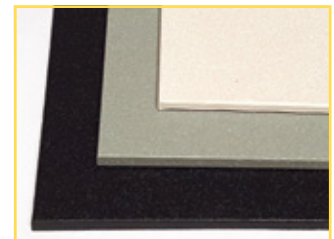

HDPE

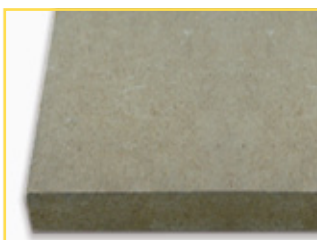

MDF



LÁMINA DE ACERO

CÓDIGO	ANCHO	COLOR
GM-120030	120 cm	Verde
⚡ EM-120010	120 cm	Verde ESD
⚡ EM-120013	120 cm	Gris ESD

CUBIERTA AUTOADHERIBLE



# PATAS Y AJUSTADORES

**AC-3829RB** 📦 500  
⚖️ 26g

**AD-3012SS** 📦 150  
⚖️ 80g

**AD-3012SL** 📦 100  
⚖️ 110g

**AD-3012SX** 📦 50  
⚖️ 164g

**AD-5012LS** 📦 150  
⚖️ 95g

**AD-5012LL** 📦 500  
⚖️ 26g

**AD-5012LX** 📦 50  
⚖️ 164g

**AS-3050MP** 📦 100  
⚖️ 36g

**AS-5030P** 📦 100  
⚖️ 105g

**CN-3010MS** 📦 400  
⚖️ 24g

**CN-3010MP** 📦 300  
⚖️ 14g

**MT-5133R** 📦 400  
⚖️ 8g

Para Tubos 1.0 mm (MP-1100)

**MT-5134P** 📦 200  
⚖️ 52g

**TL-4000** 📦 50  
⚖️ 130g

## INSERTOS

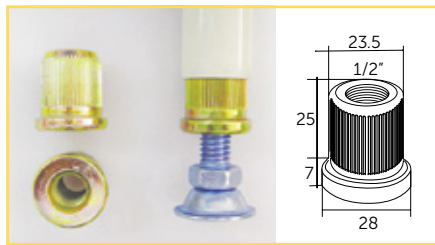

MT-5136

300  
88g

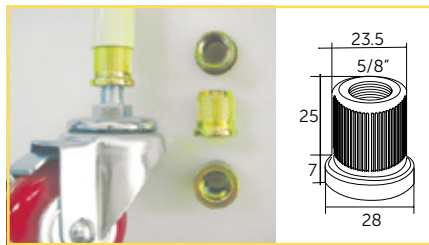

MT-5137

300  
88g

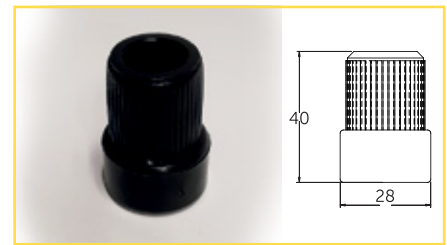

MT-5136P

200  
88g

### INSERTOS PARA AJUSTADOR

	CÓDIGO	TUBO	TIPO DE TUBO
	MT-5136	1.0 mm	Estándar
	MT-5136T2	2.0 mm	Estándar
	MT513607	0.7 mm	Estándar
	MT-5136ST07	0.7 mm	Acero Inox
	MT-5136ST11	1.1 mm	Acero Inox

### INSERTOS PARA RUEDA

	CÓDIGO	TUBO	TIPO DE TUBO
	MT-5137	1.0 mm	Estándar
	MT-5137T2	2.0 mm	Estándar
	MT513707	0.7 mm	Estándar
	MT-5137ST07	0.7 mm	Acero Inox
	MT-5137ST11	1.1 mm	Acero Inox

## CUBIERTAS PROTECTORAS PARA TUBOS



TH-0001

Cubierta Protectora Plástica Tramada

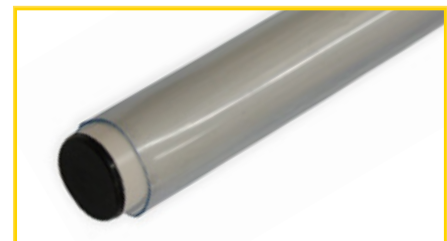

TH-0002

Cubierta Protectora Plástica Transparente

CÓDIGO	MATERIAL	LONGITUD	PESO
TH-0001	PVC	45 m / rollo	502 g / m
TH-0002	PVC	45 m / rollo	160 g / m
TH-0003	Atilon	4 m / pieza	23 g / m
TH-0005	Hule Suave	2 m / pieza	95 g / m



TH-0003

Cubierta Protectora Atilon



TH-0005

Cubierta Protectora de Hule Espuma EPDM

# MICAS PROTECTORAS

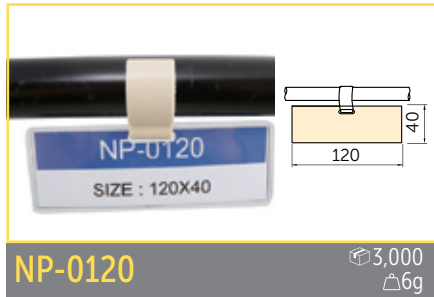

**NP-0120** 3,000  
6g

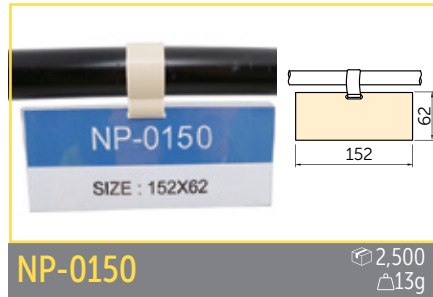

**NP-0150** 2,500  
13g



**NP-0180** 1,500  
20g

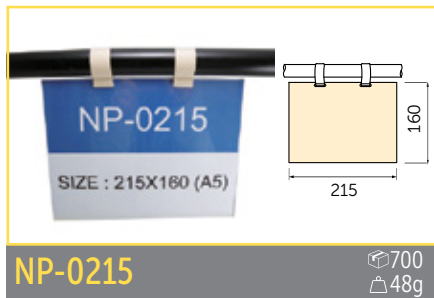

**NP-0215** 700  
48g



**NP-0220** 1,000  
28g

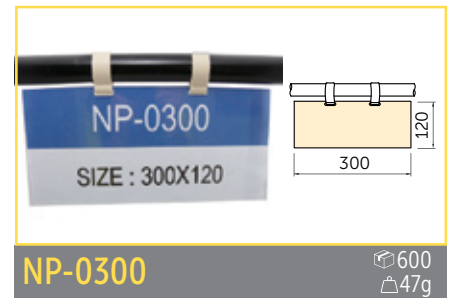

**NP-0300** 600  
47g

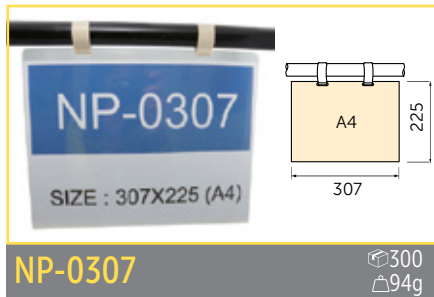

**NP-0307** 300  
94g

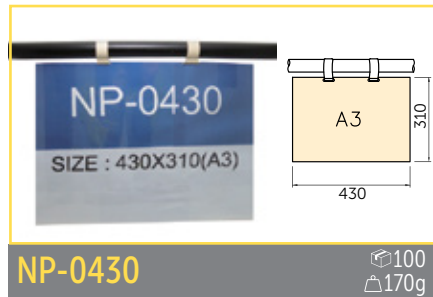

**NP-0430** 100  
170g



**NPA-110 ADHERIBLE** 3,000  
6g

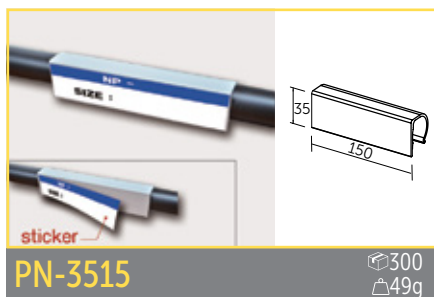

**PN-3515** 300  
49g

CÓDIGO	ALTO	ANCHO		
LH-3010CS	30	100 mm	12 g	500
LH-3015CS		150 mm	18 g	350
LH-3020CS		200 mm	24 g	300
LH-3030CS		300 mm	36 g	150

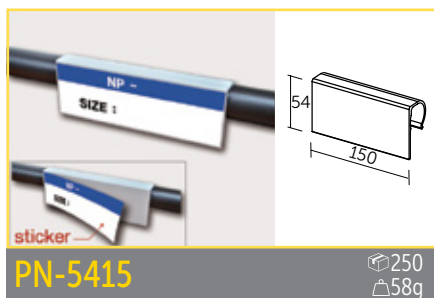

**PN-5415** 250  
58g

CÓDIGO	ALTO	ANCHO		
LH-5010CL	55	100 mm	22 g	400
LH-5015CL		150 mm	33 g	200
LH-5020CL		200 mm	44 g	200
LH-5030CL		300 mm	66 g	100

# TORNILLERÍA

WB-0610



• ZN • NI • BK

M6 x 10/25

WB- 0625



• ZN • NI • BK

M6 x 10/25

BT-0825/40/50



M8 x 25/40/50

BT-1250



1/2 x 50

NU-0600



• ZN • NI • BK

M6

NN-0800



M8

NU-1200



1/2

SC-0810/20/25/30/35



#8 x 10/20/25/30/35

SE-0810/20/25/30



#8 x 10/20/25/30

SW-0810/20/25/30

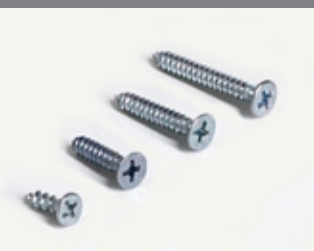

#8 x 10/20/30

SW-1020



#10 x 20

ME-1011



PARA ME-1001: 6 pzas

# ROLLERS

CÓDIGO	ESPECIFICACIÓN	MARCO	RUEDAS	ANCHO	ALTO	EJES	CAPACIDAD
PL-7001BK	Acero 36 mm	Acero (SPGI)	Negra Ø30	36 mm	34 mm	34.8 mm	200 kg/m
PL-7001WH	Acero 36 mm		Blanca Ø30	36 mm	34 mm	34.8 mm	200 kg/m
PL-3111	Acero 40 mm		Blanca Ø30	40 mm	42 mm	35.7 mm	220 kg/m
PL-3111BK	Acero 40 mm		Negra Ø30	40 mm	42 mm	35.7 mm	220 kg/m
⚡ PL-3111ED	Acero 40 mm (ESD)		Negra Ø30	40 mm	42 mm	35.7 mm	220 kg/m
PL-3111YL	Acero 40 mm		Amarilla Ø30	40 mm	42 mm	35.7 mm	220 kg/m
GP-4014WH	Acero 40 mm		Blanca Ø46	40 mm	50 mm	53.6 mm	220 kg/m
⚡ PL-6014ED	Acero 60 mm (ESD)		Negra Ø30	60 mm	34 mm	37 mm	300 kg/m
PL-6014WH	Acero 60 mm		Blanca Ø30	60 mm	34 mm	37 mm	300 kg/m
PL-6014WS	Acero 60 mm		Blanca Ø16	60 mm	27 mm	18.5 mm	300 kg/m
⚡ PL-7314ED	Acero 73 mm (ESD)		Negra Ø34	73 mm	41 mm	40 mm	350 kg/m
PL-7314WH	Acero 73 mm		Blanca Ø34	73 mm	41 mm	40 mm	350 kg/m
PL-7314WS	Acero 73 mm		Blanca Ø18	73 mm	33 mm	20 mm	350 kg/m
PL-8500	Acero 85 mm		Blanca Ø34	85 mm	44 mm	25 mm	400 kg/m



**PL-7001WT** Tramo de 4m • △1,180g



**PL-3111** Tramo de 4m • △1,125g



**GP-4014WH** Tramo de 4m • △1,102g



**PL-6014WH** Tramo de 4m • △1,250g



**PL-6014WS** Tramo de 4m • △1,293g



**PL-7314WH** Tramo de 4m • △1,910g



**PL-7314WS** Tramo de 4m • △1,910g



**PL-8500** Tramo de 4m • △1,800g

## ROLLER 36mm

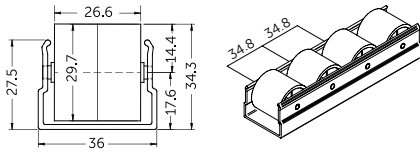

**PL-7001BK** Tramo de 4m •  $\triangle$  1,180g



**PL7001WT** Tramo de 4m •  $\triangle$  1,180g

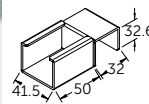
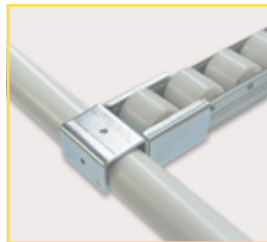

**MT-7001A**  $\square$  120  $\triangle$  138g

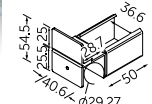
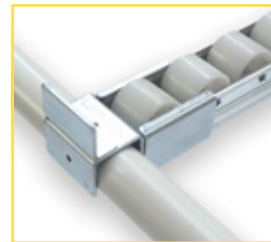

**MT-7002B**  $\square$  120  $\triangle$  160g

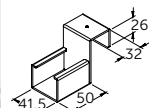
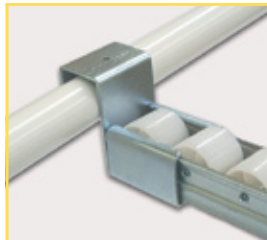

**MT-7002BW**  $\square$  120  $\triangle$  140g

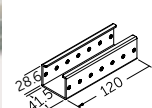

**MT-7003C**  $\square$  120  $\triangle$  200g

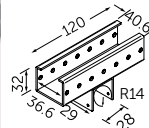
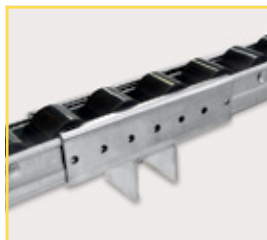

**MT-7004D**  $\square$  120  $\triangle$  252g

# ROLLER 40mm

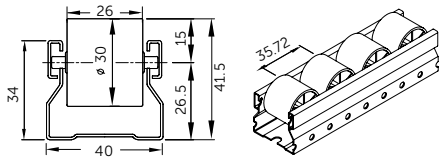

PL-3111 · PL-3111ED · PL-3114BK · PL-3111YL



**PL-3111** Tramo de 4m •  $\triangle$  1,125g



**PL-3111BK** Tramo de 4m •  $\triangle$  1,248g

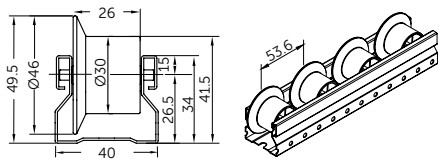

GP-4014WH



**PL-3111ED** Tramo de 4m •  $\triangle$  1,180g



**PL3111YL** Tramo de 4m •  $\triangle$  1,248g



**GP-4014WH** Tramo de 4m •  $\triangle$  1,102g

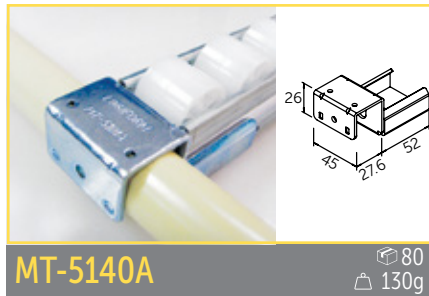

**MT-5140A**  $\triangle$  80 130g

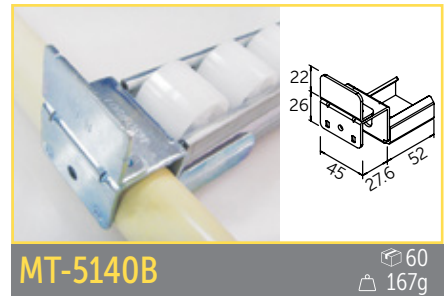

**MT-5140B**  $\triangle$  60 167g

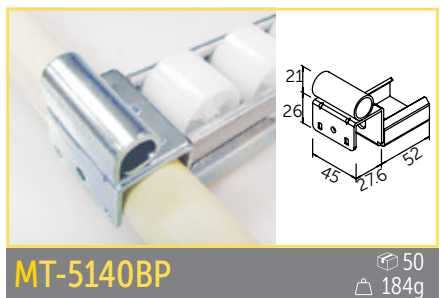

**MT-5140BP**  $\triangle$  50 184g

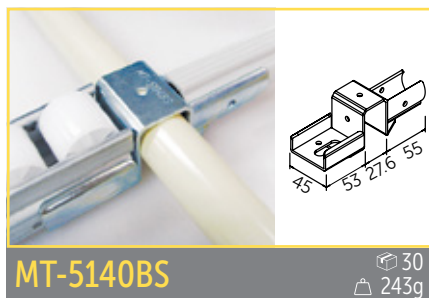

**MT-5140BS**  $\triangle$  30 243g

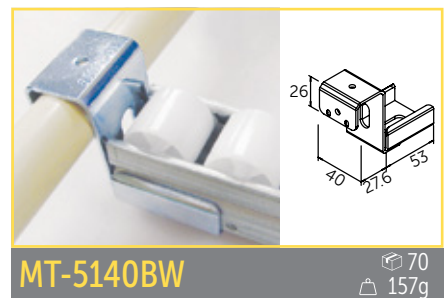

**MT-5140BW**  $\triangle$  70 157g

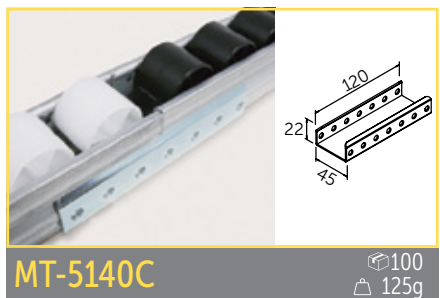

**MT-5140C**  $\triangle$  100 125g

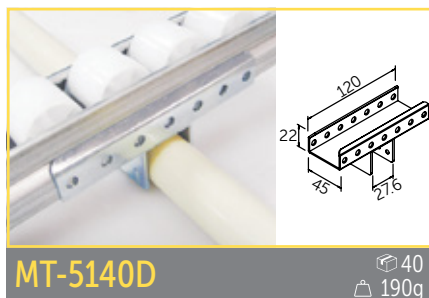

**MT-5140D**  $\triangle$  40 190g

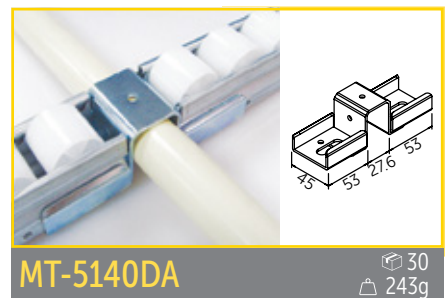

**MT-5140DA**  $\triangle$  30 243g

**⚡ ANTIESTÁTICO/ESD**

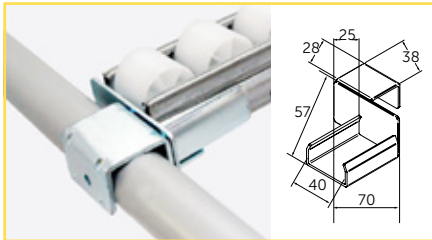

**MT-PLAL**

40  
246g

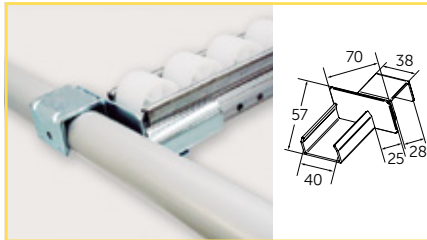

**MT-PLAR**

40  
246g

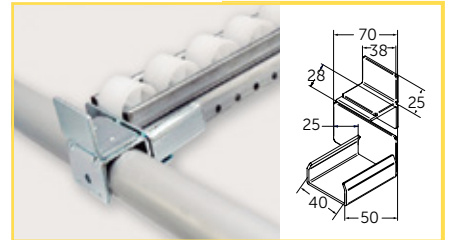

**MT-PLBL**

40  
246g

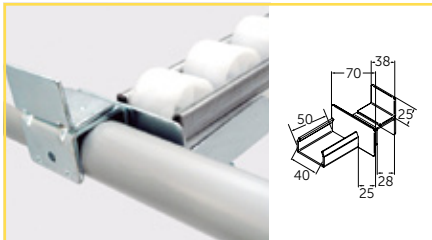

**MT-PLBR**

30  
243g

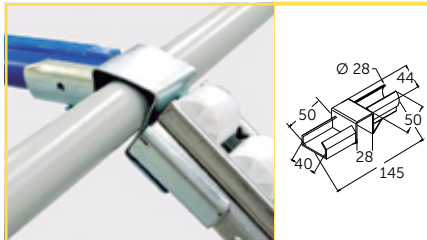

**MT-PLHN**

30  
243g

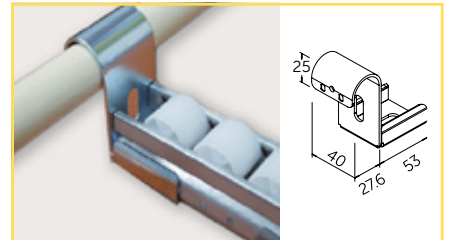

**MT-4010BR**

70  
160g

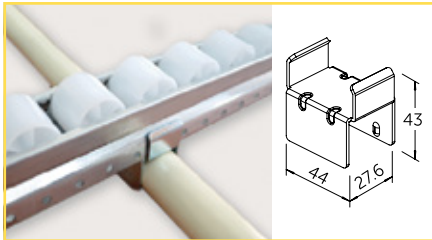

**MT-4010E**

49  
180g

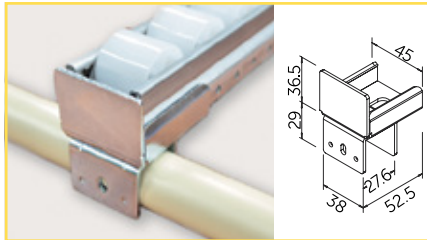

**MT-4010X**

80  
150g

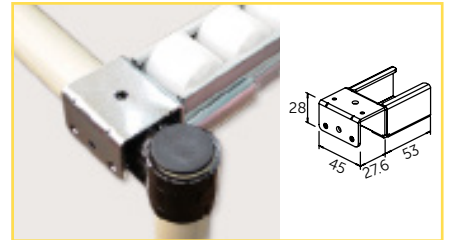

**MT-4012A**

60  
163g

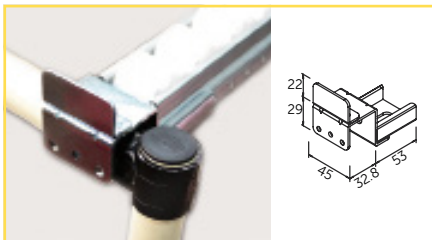

**MT-4012B**

40  
195g

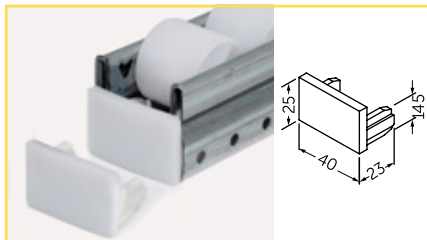

**PJ-140AL**

2,000  
6g



**PJ-1401BK**

1,000  
12g

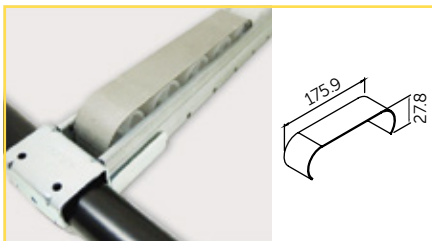

**MS-4018SV**

300  
60g



# ROLLER 60mm

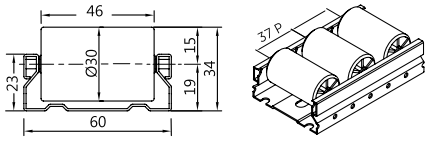

PL-6014WH · PL-6014ED



**PL-6014WH** Tramo de 4m •  $\triangle$  1,250g



**PL-6014WS** Tramo de 4m •  $\triangle$  1,293g

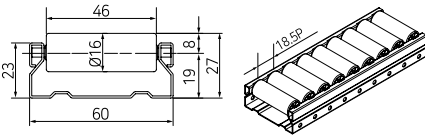

PL-6014WS



**PL-6014ED** Tramo de 4m •  $\triangle$  1,298g

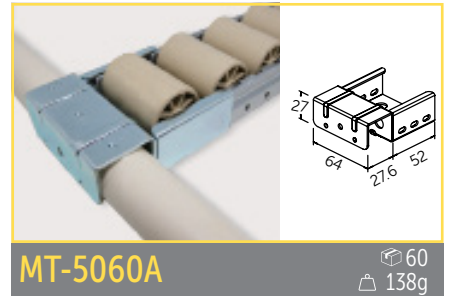

**MT-5060A**  $\triangle$  60 138g

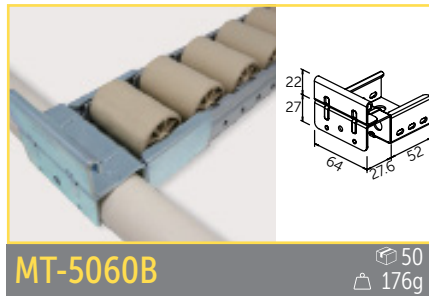

**MT-5060B**  $\triangle$  50 176g

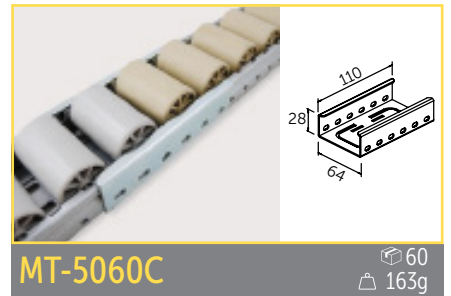

**MT-5060C**  $\triangle$  60 163g

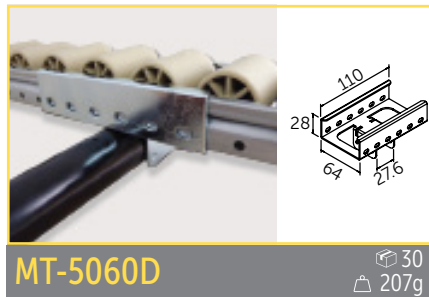

**MT-5060D**  $\triangle$  30 207g

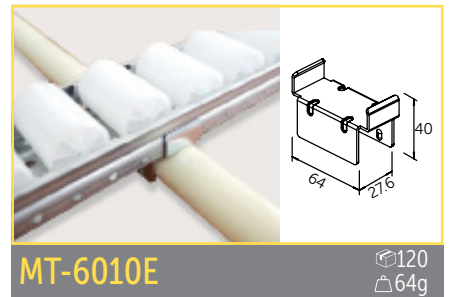

**MT-6010E**  $\triangle$  120 64g

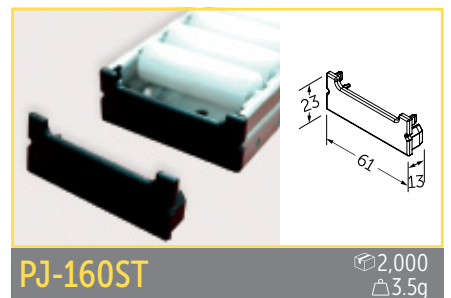

**PJ-160ST**  $\triangle$  2,000 3.5g

**⚡ ANTIESTÁTICO/ESD**

## ROLLER 73mm

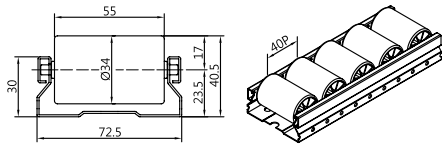

PL-7314ED



(Antes PL3114)

**PL-7314WH** Tramo de 4m •  $\triangle$  1,910g



**PL-7314WS** Tramo de 4m •  $\triangle$  1,910g

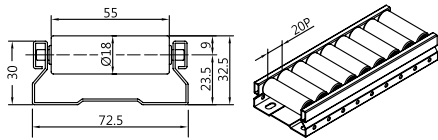

PL-7314WS



**PL-7314ED** Tramo de 4m •  $\triangle$  1,910g

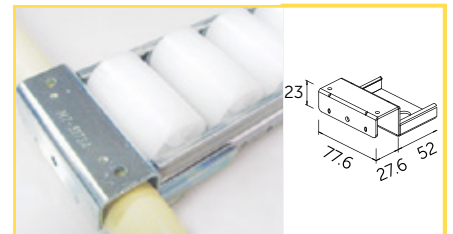

**MT-5073A**  $\triangle$  40  
 $\triangle$  198g

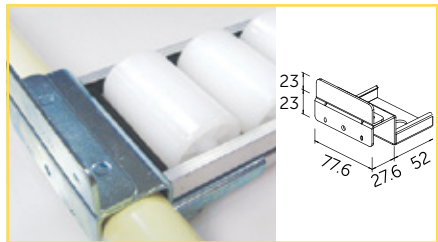

**MT-5073B**  $\triangle$  30  
 $\triangle$  250g

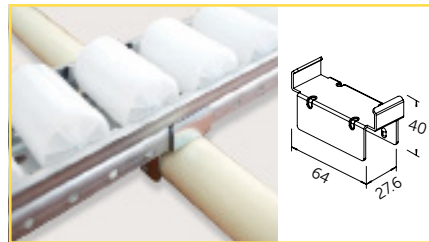

**MT-5073E**  $\triangle$  100  
 $\triangle$  76g

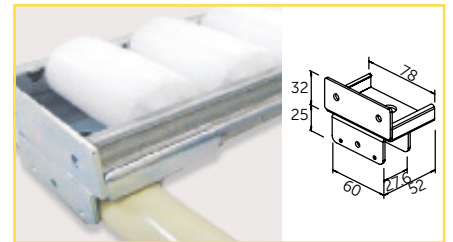

**MT-5073X**  $\triangle$  50  
 $\triangle$  210g

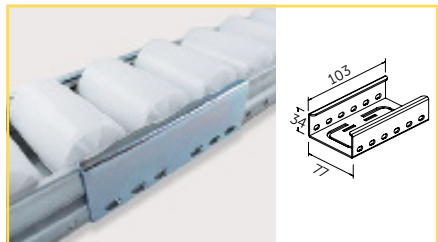

**MT-5073C**  $\triangle$  40  
 $\triangle$  204g

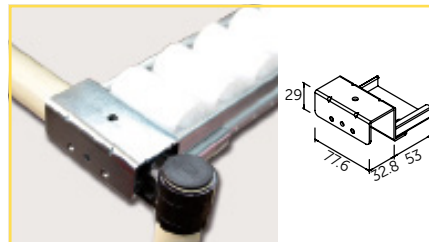

**MT-7312A**  $\triangle$  40  
 $\triangle$  273g

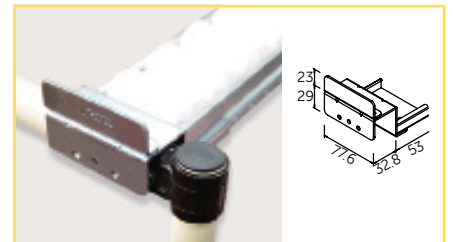

**MT-7312B**  $\triangle$  30  
 $\triangle$  360g

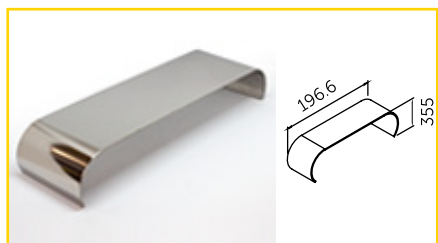

**MS-7318SV**  $\triangle$  100  
 $\triangle$  126g

ANTIESTÁTICO/ ESD

# ROLLER 85mm

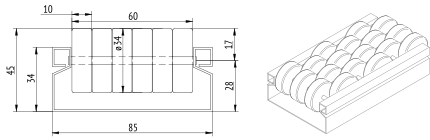

PL-8500



PL-8500 Tramo de 4m •  $\triangle$ 1,800g

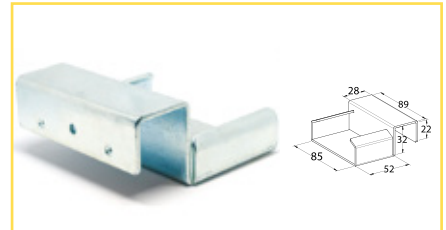

MT-8500A  $\triangle$  70  $\triangle$  18g

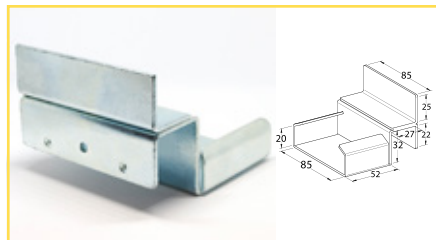

MT-8500B  $\triangle$  50  $\triangle$  20g

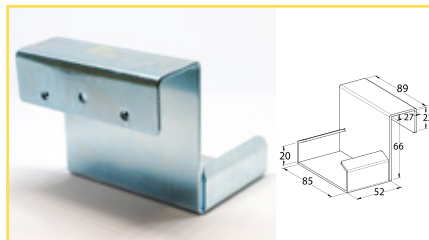

MT-8500BW  $\triangle$  80  $\triangle$  19g

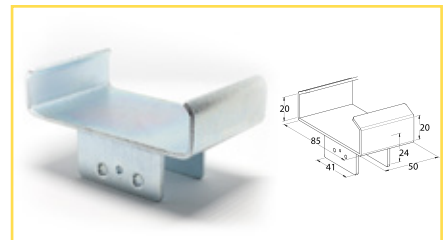

MT-8500D  $\triangle$  80  $\triangle$  16g

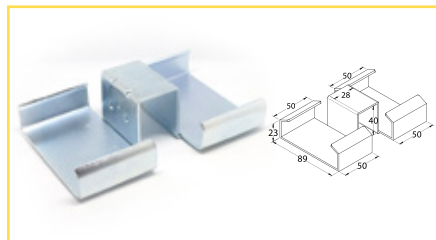

MT-8500DA  $\triangle$  34  $\triangle$  30g

# MONTURAS TUBO SLIDE

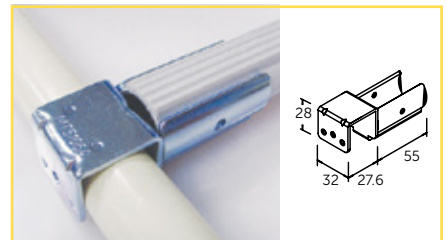

MT-5160A  $\triangle$  100  $\triangle$  122g

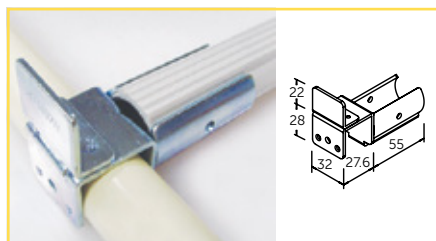

MT-5160B  $\triangle$  80  $\triangle$  145g

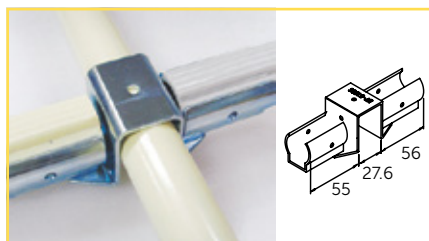

MT-5160C  $\triangle$  30  $\triangle$  240g

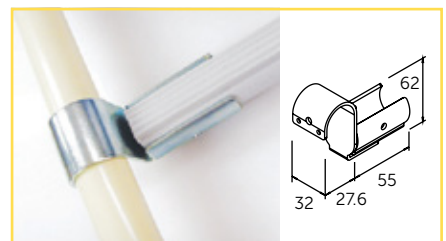

MT-5160D  $\triangle$  80  $\triangle$  138g

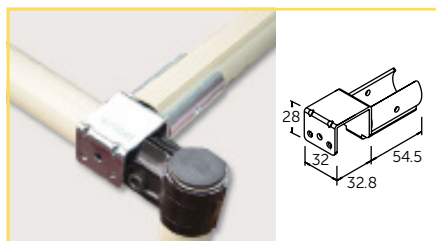

MT-5160E  $\triangle$  100  $\triangle$  120g

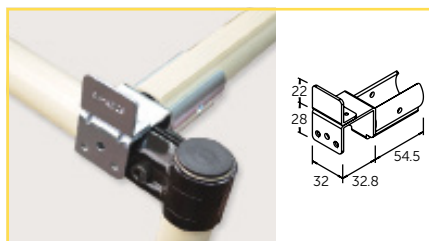

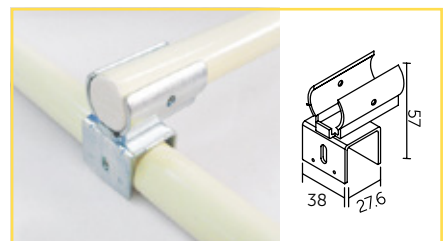

MT-5160F  $\triangle$  80  $\triangle$  148g



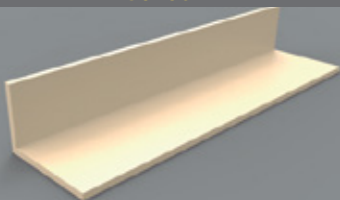
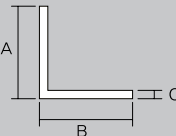
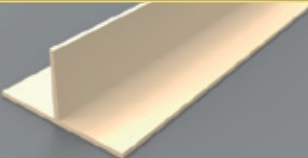
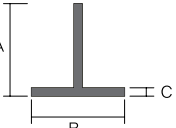

MT-5160G  $\triangle$  90  $\triangle$  132g

# ÁNGULOS Y GUÍAS

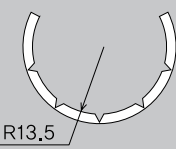
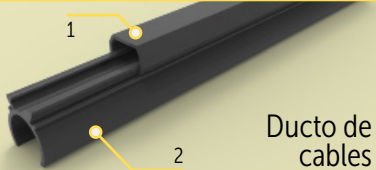
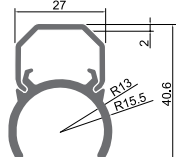
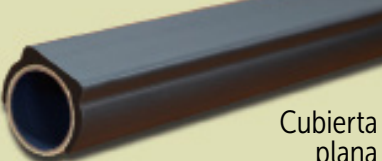
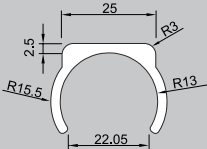
ÁNGULOS	TIPO	TAMAÑO	CÓDIGO	A	B	C	PESO	CANTIDAD
	"L"		PA-2501	30	50	T3	340 g/m	10 x atado
			PA-2502	80	90		723 g/m	
			PA-2503	50	50		586 g/m	
			PA-2503A	50	75	706 g/m		
			PA-2504	50	100	833 g/m		
			PA-2505	50	150	1,180 g/m		
PA-2505A	50	200	1,430 g/m					
	"T"		PA-2506	50	100	T3	793 g/m	
			PA-2506A	150	50	T4	1,121 g/m	
			PA-2507	100	60	T5	1,106 g/m	

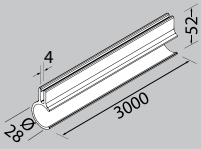
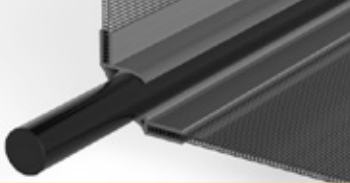
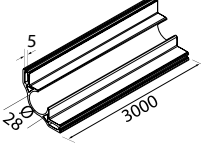
CUBIERTAS y CANALETAS	TIPO	TAMAÑO	CÓDIGO	ESPESOR	PESO
	"C"		PA-2509 ○ IV ○ GR	T3	223 g/m
 Ducto de cables	"B"		① CD-3000T	-	158 g/m
			② CD-3000B		282 g/m
 Cubierta plana	-		PA-4028B ○ IV ○ GR ● BK	T2.5	280 g/m

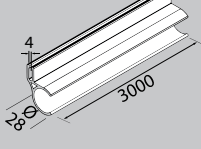
GUÍAS PARA SUPERFICIES	TIPO	TAMAÑO	CÓDIGO	PESO	CANTIDAD
	"T"		SG-01	450 g/m	8x atado
	"C"		SG-02	740 g/m	10x atado
	"L"		SG-03	490 g/m	10x atado

# GUÍAS PARA ROLLER

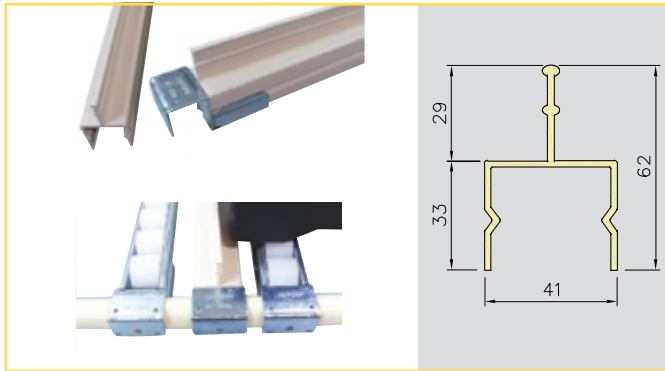

**PA-240A**

Para Roller PL-3111

Atados de 10  
Peso: 619 g/m  
Longitud: 3m

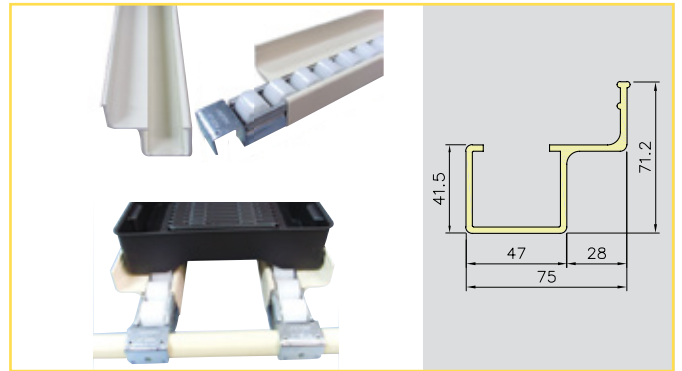

**PA-240B**

Para Roller PL-3111

Atados de 10  
Peso: 740 g/m  
Longitud: 3m

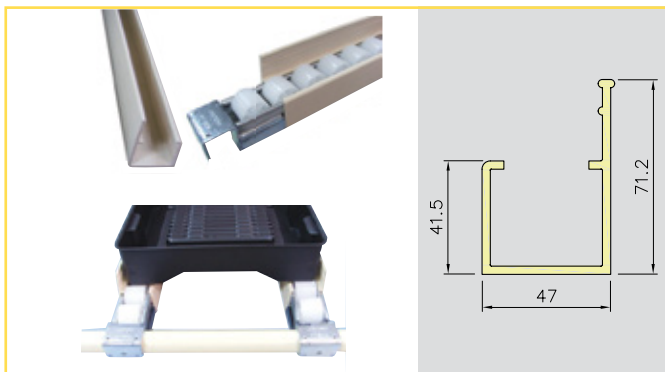

**PA-240C**

Para Roller PL-3111

Atados de 10  
Peso: 640 g/m  
Longitud: 3m

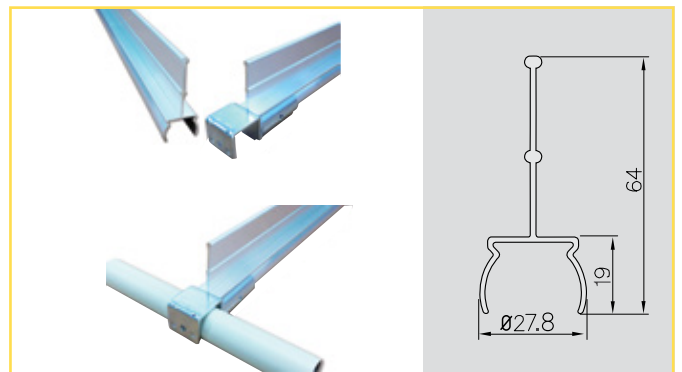

**PA-240E**

Aluminio

Atados de 10  
Peso: 1,688 g/m  
Longitud: 4m

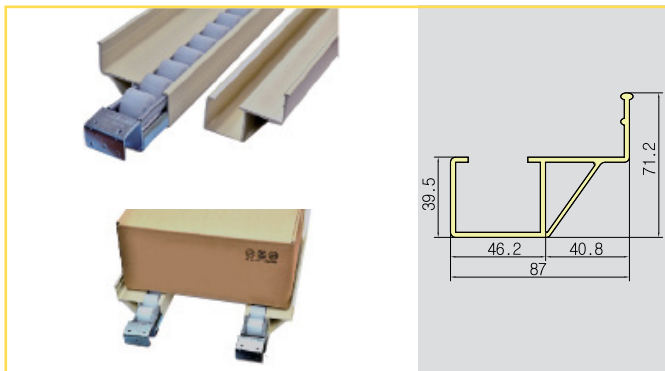

**PA-412B**

Para Roller PL-3111

Atados de 10  
Peso: 906 g/m  
Longitud: 3m

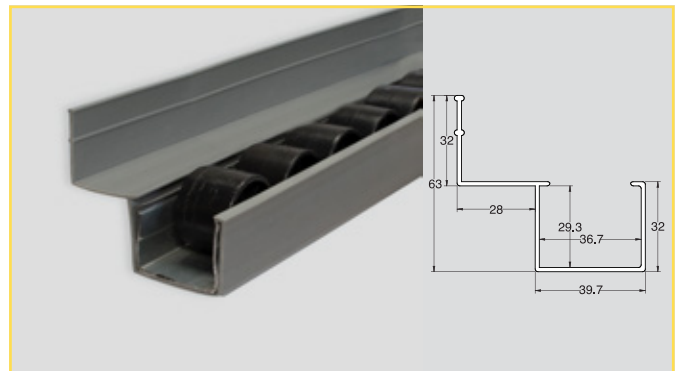

**PA-7001B**

Para Roller PL-7001

Atados de 10  
Peso: 906 g/m  
Longitud: 3m

# LeanMDC® RODAMIENTOS

Si requiere que su estructura sea móvil, puede escoger entre varios tipos de ruedas dependiendo de las condiciones de piso, carga y presupuesto.

Carga práctica = Capacidad de carga de una rueda x número de ruedas utilizadas x 0.33

La carga práctica corresponde a la carga total que podrá colocar en su Estructura Lean. Tiene un factor de seguridad del 33% para incluir el peso del rack o estructura.



## RUEDA CON TORNILLO CARGA MÁXIMA DE 124 KG



## RUEDA DE PLACA CARGAS MAYORES A 100 KG

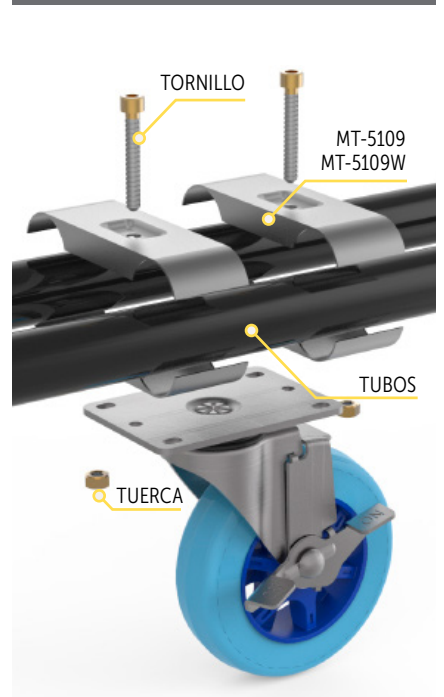









## CON TORNILLO PARA CARGAS LIVIANAS













ARTÍCULO	CÓDIGO DEL PRODUCTO	TIPO	pulgadas (mm)	pulgadas	pulgadas (mm)	mm	kg (max)	RUEDA	PESO kg	CANTIDAD POR CAJA	
	CT-702S	GIRATORIA	2"	1/2	20	44	72	POLIURETANO	0.16	160	
	CT-703S		3"	5/8	32	73	108		100		
	CT-704S		4"	5/8	32	89	133		105		
	CT-702B	GIRATORIA CON FRENO	2"	1/2	20	44	72		0.16	160	
	CT-703B		3"	5/8	32	73	108		100		
	CT-704B		4"	5/8	32	89	133		105		
	CT-703SE	GIRATORIA	3"	5/8	32	73	108		100	0.69	32
	CT-704SE		4"	5/8		89	133		105		
	CT-703BE	GIRATORIA CON FRENO	3"	5/8	32	73	108		100	0.75	32
	CT-704BE		4"	5/8		89	133		105		

ANTIESTÁTICO/ ESD

## CON EXPANSOR











ARTÍCULO	CÓDIGO DEL PRODUCTO	TIPO	 pulgadas (mm)	 pulgadas	 pulgadas (mm)	 mm	 mm	 kg (max)	RUEDA	PESO kg	CANTIDAD POR CAJA
	CT-703SEX	GIRATORIA	3"	1 1/4	32	73	108	90	HULE TERMOPLÁSTICO	0.90	20
	CT-704SEX		4"			89	133	124			
	CT-703BEX	GIRATORIA CON FRENO TOTAL	3"			73	108	90			
	CT-704BEX		4"			89	133	124			
	CT-703BLEX	GIRATORIA CON FRENO LATERAL	3"			73	108	90			
	CT-704BLEX		4"			89	133	124			

## DE PLACA PARA CARGAS LIVIANAS









ARTÍCULO	CÓDIGO DEL PRODUCTO	TIPO	 pulgadas (mm)	 pulgadas (mm)	 mm	 mm	 kg (max)	 mm	 mm	RUEDA	PESO kg	CANTIDAD POR CAJA	
	CT-713RL	RÍGIDA	3"	32	NA	104	100	95 x 64	76 a 73 x 45	POLIURETANO	0.54	32	
	CT-714RL		4"			129	105				0.83	24	
	CT-715RL		5"			156	115				0.74	20	
	CT-713SL	GIRATORIA	3"			73	104				100	0.83	32
	CT-714SL		4"			89	129				105	0.94	24
	CT-715SL		5"			101	156				115	1.03	20
	CT-713BL	GIRATORIA CON FRENO	3"			73	104				100	0.88	32
	CT-714BL		4"			89	129				105	1.03	24
	CT-715BL		5"			101	156				115	1.12	20
	CT-713RE	RÍGIDA	3"	104	56	0.58	32						
	CT-714RE		4"	NA	129	75	0.88	24					
	CT-715RE		5"	156	80	1.17	20						
	CT-713SE	GIRATORIA	3"	73	104	56	0.87	32					
	CT-714SE		4"	89	129	75	1.05	24					
	CT-715SE		5"	101	156	80	1.24	20					
	CT-713BE	GIRATORIA CON FRENO	3"	73	104	56	0.93	32					
	CT-714BE		4"	89	129	75	1.32	24					
	CT-715BE		5"	101	156	80	1.72	20					

 ANTIESTÁTICO/ ESD











## DE PLACA PARA CARGAS MEDIANAS

ARTÍCULO	CÓDIGO DEL PRODUCTO	TIPO	 pulgadas (mm)	 pulgadas (mm)	 mm	 mm	 kg (max)	 mm	 mm	RUEDA	PESO kg	CANTIDAD POR CAJA						
	CT-714RH	RÍGIDA	4"	38		137	200	114 x 102	92 a 76 x 76 a 66	POLIURETANO	1.72	10						
	CT-715RH		5"	40	NA	165	250				2.15	10						
	CT-716RH		6"	44		190	270				2.63	8						
	CT-714SH	GIRATORIA	4"	38	82	137	200				114 x 102	92 a 76 x 76 a 66	POLIURETANO	1.85	10			
	CT-715SH		5"	40	90	165	250							2.58	10			
	CT-716SH		6"	44	108	190	270							2.94	8			
	CT-714BH	GIRATORIA CON FRENO LATERAL	4"	38	82	137	200							114 x 102	92 a 76 x 76 a 66	POLIURETANO	1.85	10
	CT-715BH		5"	40	90	165	250										2.77	10
	CT-716BH		6"	44	108	190	270										3.14	8

## CON TORNILLO DE ALTO POLIURETANO CUARTO LIMPIO











ARTÍCULO	CÓDIGO DEL PRODUCTO	TIPO	 pulgadas (mm)	 pulgadas	 pulgadas (mm)	 mm	 mm	 kg (max)	RUEDA	PESO kg	CANTIDAD POR CAJA			
	CT-703SP	GIRATORIA	3"	5/8	32	78	104	56	ALTO POLIURETANO	0.62	32			
	CT-704SP		4"			89	129	75		0.75	24			
	CT-705SP		5"			101	156	80		0.88	20			
	CT-703BP	GIRATORIA CON FRENO LATERAL	3"			5/8	32	78		104	56	ALTO POLIURETANO	0.68	32
	CT-704BP		4"					89		129	75		0.84	24
	CT-705BP		5"					101		156	80		0.96	20

## DE PLACA DE ALTO POLIURETANO CUARTO LIMPIO









ARTÍCULO	CÓDIGO DEL PRODUCTO	TIPO	 pulgadas (mm)	 pulgadas (mm)	 mm	 mm	 kg (max)	 mm	 mm	RUEDA	PESO kg	CANTIDAD POR CAJA											
	CT-713RP	RÍGIDA	3"	32	NA	104	56	95 x 64	76 a 73 x 45	ALTO POLIURETANO	0.45	32											
	CT-714RP		4"			129	75				0.55	24											
	CT-715RP		5"			156	80				0.66	20											
	CT-713SP	GIRATORIA	3"			32	NA				78	104	95 x 64	76 a 73 x 45	ALTO POLIURETANO	0.74	32						
	CT-714SP		4"								89	129				75	0.84	24					
	CT-715SP		5"								101	156				80	0.97	20					
	CT-713BP	GIRATORIA CON FRENO LATERAL	3"								32	NA				78	104	95 x 64	76 a 73 x 45	ALTO POLIURETANO	0.80	32	
	CT-714BP		4"													89	129				75	0.93	24
	CT-715BP		5"													101	156				80	1.06	20



## DE PLACA CON AMORTIGUAMIENTO

ARTÍCULO	CÓDIGO DEL PRODUCTO	TIPO	 pulgadas (mm)	 pulgadas (mm)	 mm	 mm	 kg (max)	 mm	 mm	RUEDA	PESO kg	CANTIDAD POR CAJA
	CT-726RC	RIGIDA	6"							POLIURETANO	5.146	4
	CT-726SC	GIRATORIA	6"	48	128	203	360	160 x 115	129 x 72.5		5.876	
	CT-726BC	GIRATORIA CON FRENO	6"								6.178	

## CON ANILLO DE AGARRE

ARTÍCULO	CÓDIGO DEL PRODUCTO	TIPO	 pulgadas (mm)	 pulgadas (mm)	 mm	 mm	 kg (max)	ENROSCADO	RUEDA	PESO kg	CANTIDAD POR CAJA
	CT-703RR	RIGIDA	3"						POLIURETANO	0.44	40
	CT-703SR	GIRATORIA	3"	32	70	100	75	ø11 X 38mm		0.5	
	CT-703BR	GIRATORIA CON FRENO LATERAL	3"							0.56	

## INSERTOS PARA RUEDAS CON ANILLO DE AGARRE



25.6

45

5

29

**CI-1111SP**      Peso x pza: 22.6 g

Para Tubo Inoxidable 1.1 mm espesor



23.7

45

5

29

**CI-1110LP**      Peso x pza: 22.6 g

Para Tubo ABS 1.0 mm espesor

## GAVETAS

Las gavetas maximizan la capacidad de almacenaje y organizan el centro de trabajo. Facilitan la clasificación en colores y tamaños, resistentes a la corrosión, de fácil limpieza y acceso, resistentes a descargas eléctricas menores a 200 W.



CÓDIGO	LARGO	ANCHO	ALTO
510001	14.5 cm	10.5 cm	7.6 cm
510002	17.0 cm	10.5 cm	7.6 cm
510003	18.5 cm	11.8 cm	7.6 cm
510004	24.0 cm	15.0 cm	13.5 cm
510005	27.5 cm	16.5 cm	12.5 cm
510006	27.6 cm	21.0 cm	17.5 cm
510007	37.7 cm	23.5 cm	17.8 cm
510008	30.0 cm	20.0 cm	15.7 cm
510009	50.0 cm	30.9 cm	20.0 cm
510010	37.0 cm	42.0 cm	17.7 cm
510011	37.0 cm	12.0 cm	8.5 cm
510012	60.4 cm	12.0 cm	8.5 cm
510013	59.5 cm	28.0 cm	10.5 cm
510014	50.3 cm	30.0 cm	20.0 cm

Los colores de las gavetas y los contenedores se encuentran sujetos a disponibilidad. Verificar disponibilidad en:

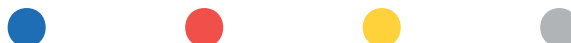

## CONTENEDORES

	<p>Útil en la logística de todo tipo de industria y maquilas. Capacidad de carga: 15 kg. Apilable. Tapadera (opcional).</p> <p><b>Largo: 49.8 cm</b> <b>Ancho: 34.0 cm</b> <b>Altura: 26.0 cm</b></p>	<p><b>510014</b>      ○ ○      CAJA QUEBEC</p>
	<p>Disponble con soporte para etiquetas. Útil para los procesos de armado en las cadenas de producción donde se requiere la utilización de diferentes componentes. Fácil de trasladar y/o almacenar. Capacidad de carga: 15 kg - Apilable.</p> <p><b>Largo: 38.0 cm</b> <b>Ancho: 24.0 cm</b> <b>Altura: 10.5 cm</b></p>	<p><b>510015</b>      ○ ○      CAJA INDUSTRIAL NO.1</p>
	<p>Capacidad de carga: 15 kg. Apilable.</p> <p><b>Largo: 38.0 cm</b> <b>Ancho: 24.0 cm</b> <b>Altura: 10.5 cm</b></p>	<p><b>510015ESD</b>      ○ ○      CAJA INDUSTRIAL NO.1</p>
	<p>Capacidad de carga: 20 kg. Apilable.</p> <p><b>Largo: 48.0 cm</b> <b>Ancho: 38.0 cm</b> <b>Altura: 15.0 cm</b></p>	<p><b>510016</b>      ○ ○      CAJA INDUSTRIAL NO.2</p>
	<p>Capacidad de carga: 20 kg. Apilable.</p> <p><b>Largo: 48.0 cm</b> <b>Ancho: 38.0 cm</b> <b>Altura: 15.0 cm</b></p>	<p><b>510016ESD</b>      ○ ○      CAJA INDUSTRIAL NO.2</p>
	<p>Capacidad de carga: 25 kg. Apilable.</p> <p><b>Largo: 48.3 cm</b> <b>Ancho: 38.0 cm</b> <b>Altura: 10.5 cm</b></p>	<p><b>510017</b>      ○ ○      CAJA INDUSTRIAL NO.3</p>
	<p>Capacidad de carga: 25 kg. Apilable.</p> <p><b>Largo: 48.3 cm</b> <b>Ancho: 38.0 cm</b> <b>Altura: 10.5 cm</b></p>	<p><b>510017ESD</b>      ○ ○      CAJA INDUSTRIAL NO.3</p>
	<p>Capacidad de carga: 50 kg. Apilable.</p> <p><b>Largo: 76.5 cm</b> <b>Ancho: 48.0 cm</b> <b>Altura: 20.0 cm</b></p>	<p><b>510018</b>      ○ ○      CAJA INDUSTRIAL NO.4</p>
	<p>Capacidad de carga: 50 kg. Apilable.</p> <p><b>Largo: 76.5 cm</b> <b>Ancho: 48.0 cm</b> <b>Altura: 20.0 cm</b></p>	<p><b>510018ESD</b>      ○ ○      CAJA INDUSTRIAL NO.4</p>
	<p>Capacidad de carga: 30 kg. Apilable.</p> <p><b>Largo: 44.8 cm</b> <b>Ancho: 27.3 cm</b> <b>Altura: 12.0 cm</b></p>	<p><b>510015B</b>      ○ ○      CAJA INDUSTRIAL BAJA NO.1</p>

## CONTENEDORES

⚡ ANTIESTÁTICO

	Capacidad de carga: 30 kg. Apilable.
	Largo: 44.8 cm Ancho: 27.3 cm Altura: 12.0 cm
⚡	
<b>510015BESD</b>	○ ○ CAJA INDUSTRIAL BAJA NO.1

	Capacidad de carga: 30 kg. Apilable.
	Largo: 45.0 cm Ancho: 27.0 cm Altura: 15.3 cm
○ ○	
<b>510016A</b>	○ ○ CAJA INDUSTRIAL ALTA NO.2

	Capacidad de carga: 30 kg. Apilable.
	Largo: 45.0 cm Ancho: 27.0 cm Altura: 15.3 cm
⚡	
<b>510016AESD</b>	○ ○ CAJA INDUSTRIAL ALTA NO.2

	Capacidad de carga: 10 kg. Apilable.
	Largo: 29.5 cm Ancho: 18.5 cm Altura: 9.4 cm
○ ○	
<b>510046</b>	○ ○ CAJA TIER ONE 1

	Capacidad de carga: 10 kg. Apilable.
	Largo: 29.5 cm Ancho: 18.5 cm Altura: 9.4 cm
⚡	
<b>510046ESD</b>	○ ○ CAJA TIER ONE 1

	Capacidad de carga: 25 kg. Apilable.
	Largo: 37.3 cm Ancho: 29.7 cm Altura: 9.4 cm
○ ○	
<b>510047</b>	○ ○ CAJA TIER ONE 2

	Capacidad de carga: 25 kg. Apilable.
	Largo: 37.3 cm Ancho: 29.7 cm Altura: 9.4 cm
⚡	
<b>510047ESD</b>	○ ○ CAJA TIER ONE 2

	Capacidad de carga: 25 kg. Apilable. Tapadera (opcional).
	Largo: 50.5 cm Ancho: 35.4 cm Altura: 30.6 cm
○ ○	
<b>510048</b>	○ ○ CAJA TIER ONE 3

	Capacidad de carga: 25 kg. Apilable. Tapadera (opcional).
	Largo: 50.5 cm Ancho: 35.4 cm Altura: 30.6 cm
⚡	
<b>510048ESD</b>	○ ○ CAJA TIER ONE 3

	Capacidad de carga: 15 kg. Apilable. Tapadera (opcional).
	Largo: 52.4 cm Ancho: 34.2 cm Altura: 30.4 cm
○ ○	
<b>510049</b>	○ ○ CAJA TIER ONE 4

## CONTENEDORES



Capacidad de carga: 15 kg  
Apilable.  
Tapadera (opcional).

**Largo: 52.4 cm**  
**Ancho: 34.2 cm**  
**Altura: 30.4 cm**

**510014ESD** ○ ○ CAJA TIER ONE 4



Útil en la logística de todo tipo de industria y maquilas.  
Capacidad de carga: 10 kg.  
Apilable con tapa y anidable con la tapa abierta.

**Largo: 50.0 cm**  
**Ancho: 30.0 cm**  
**Altura: 21.0 cm**

**510019** ○ ○ CAJA CANADA CON TAPA



Cierre de tapa con bisagras ayudando que la misma se maneje junto con la caja. Útil en la logística de todo tipo de industria y maquilas.  
Capacidad de carga: 35 kg  
Apilable y Anidable.

**Largo: 61.5 cm**  
**Ancho: 49.0 cm**  
**Altura: 32.0 cm**

**510021** ○ ○ CAJA DE BISAGRA 60-50 CON TAPA



Cierre de tapa con bisagras ayudando que la misma se maneje junto con la caja. Útil en la logística de todo tipo de industria y maquilas.  
Capacidad de carga: 15 kg  
Apilable y Anidable.

**Largo: 50.3 cm**  
**Ancho: 30.0 cm**  
**Altura: 22.1 cm**

**510022** ○ ○ CAJA DE BISAGRA 50-21 CON TAPA



Cierre de tapa con bisagras ayudando que la misma se maneje junto con la caja. Útil en la logística de todo tipo de industria y maquilas.  
Capacidad de carga: 30 kg  
Apilable y Anidable.

**Largo: 60.0 cm**  
**Ancho: 40.0 cm**  
**Altura: 32.0 cm**

**510023** ○ ○ CAJA DE BISAGRA 60-32 CON TAPA



Útil en la logística de todo tipo de industria y maquilas.  
Capacidad de carga: 10 kg.  
Apilable con tapa y anidable con la tapa abierta.

**Largo: 50.0 cm**  
**Ancho: 30.0 cm**  
**Altura: 21.0 cm**

**510026** ○ ○ CAJA CANADA CON TAPA



Capacidad de carga: 60 kg.  
Apilable y Anidable.

**Largo: 78.0 cm**  
**Ancho: 45.0 cm**  
**Altura: 35.0 cm**

**510024** ○ CAJA ENFILABLE CALADA C/ASA METAL



Capacidad de carga: 70 kg.  
Apilable y Anidable.

**Largo: 77.1 cm**  
**Ancho: 44.1 cm**  
**Altura: 34.8 cm**

**510025** ○ ○ CAJA ENFILABLE CERRADA C/ASA METAL



Capacidad de carga: 35 kg.  
Apilable y Anidable.  
Piso liso con o sin desagüe.  
Tapadera (opcional).

**Largo: 60.0 cm**  
**Ancho: 40.0 cm**  
**Altura: 28.0 cm**

**510026** ○ ○ ○ CAJA MONTREAL CALADA 28



Permite su amarre en la estiba, 2 ojillos en tapa y cesta para cinto de seguridad. Útil en el transporte y almacenaje, protege y evita el maltrato y faltantes de productos.  
Piso liso con o sin desagüe - Capacidad de carga: 35 kg - Apilable y Anidable  
Tapadera (opcional).

**Largo: 60.0 cm · Ancho: 40.0 cm**  
**Altura: 28.0 cm**

**510027** ○ ○ ○ CAJA MONTREAL CERRADA 28

## CONTENEDORES

⚡ ANTIESTÁTICO

	<p>Permite su amarre en la estiba, 2 ojillos en tapa y cesta para cintos de seguridad. Útil en el transporte y almacenaje, protege y evita el maltrato y faltantes de productos. Piso liso con o sin desagüe · Capacidad de carga: 25 kg · Apilable y Anidable Tapadera (opcional). <b>Largo: 60.0 cm · Ancho: 40.0 cm</b> <b>Altura: 20.7 cm</b></p>		<p>Piso reforzado con o sin desagüe Capacidad de carga: 15 kg Apilable con las asas metálicas, anidable bajando las asas. <b>Largo: 51.0 cm</b> <b>Ancho: 33.5 cm</b> <b>Altura: 14.8 cm</b></p>
<p><b>510028</b> ○ ○ ○ CAJA MONTREAL 20 CON TAPA</p>	<p><b>510029</b> ○ CAJA OTAWA ENFILABLE DE 20</p>		
	<p>Piso reforzado con o sin desagüe Capacidad de carga: 15 kg Apilable con las asas metálicas, anidable bajando las asas. <b>Largo: 51.0 cm</b> <b>Ancho: 33.5 cm</b> <b>Altura: 14.8 cm</b></p>		<p>Piso reforzado Capacidad de carga: 30 kg Apilable y Anidable. Tapadera (opcional). <b>Largo: 60.0 cm</b> <b>Ancho: 40.0 cm</b> <b>Altura: 28.0 cm</b></p>
<p><b>510030</b> ○ CAJA OTAWA ENFILABLE DE 28</p>	<p><b>510031</b> ○ ○ ○ CAJA TORONTO CALADA CON TAPA</p>		
	<p>Piso reforzado Capacidad de carga: 35 kg Apilable y Anidable. Tapadera (opcional). <b>Largo: 60.0 cm</b> <b>Ancho: 40.0 cm</b> <b>Altura: 28.0 cm</b></p>		<p>Útil en la logística de almacenaje de cualquier tipo de producto, aprovechando al máximo el espacio en los procesos de producción al pie de máquina y en el traslado de sus productos. Capacidad de carga: 300 kg Ruedas y/o tapadera (opcionales). <b>Largo: 80.0 cm · Ancho: 80.0 cm</b> <b>Altura: 65.0 cm</b></p>
<p><b>510032</b> ○ ○ ○ CAJA TORONTO CERRADA CON TAPA</p>	<p><b>510033</b> ○ CONTENEDOR MÉXICO MEDIANO CERRADO</p>		
	<p>Útil en la logística de almacenaje de cualquier tipo de producto aprovechando al máximo el espacio en los procesos de producción al pie de máquina y en el traslado de sus productos. Capacidad de carga: 300 kg <b>Largo: 80.0 cm</b> <b>Ancho: 80.0 cm</b> <b>Altura: 80.0 cm</b></p>		<p>Capacidad de carga: 250 kg Apilable. <b>Largo: 83.0 cm</b> <b>Ancho: 60.0 cm</b> <b>Altura: 58.0 cm</b></p>
<p><b>510034</b> ○ ○ ○ CONTENEDOR MÉXICO CERRADO</p>	<p><b>510035</b> ○ ○ ○ CONTENEDOR MILANO CALADO</p>		
	<p>Útil en la logística de almacenaje de cualquier tipo de producto aprovechando al máximo el espacio en los procesos de producción al pie de máquina y en el traslado de sus productos. Capacidad de carga: 250 kg <b>Largo: 80.0 cm</b> <b>Ancho: 80.0 cm</b> <b>Altura: 80.0 cm</b></p>		<p>Capacidad de carga: 200 kg Apilable. <b>Largo: 83.0 cm</b> <b>Ancho: 60.0 cm</b> <b>Altura: 58.0 cm</b></p>
<p><b>510036</b> ○ CONTENEDOR MÉXICO CALADO</p>	<p><b>510037</b> ○ CONTENEDOR MILANO CERRADO</p>		

## CENTRO PARA CARRO "Z"

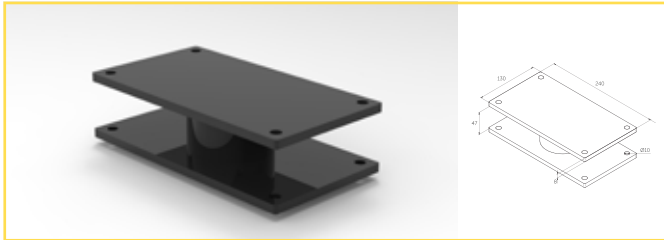

PB-240

2  
4.9kg

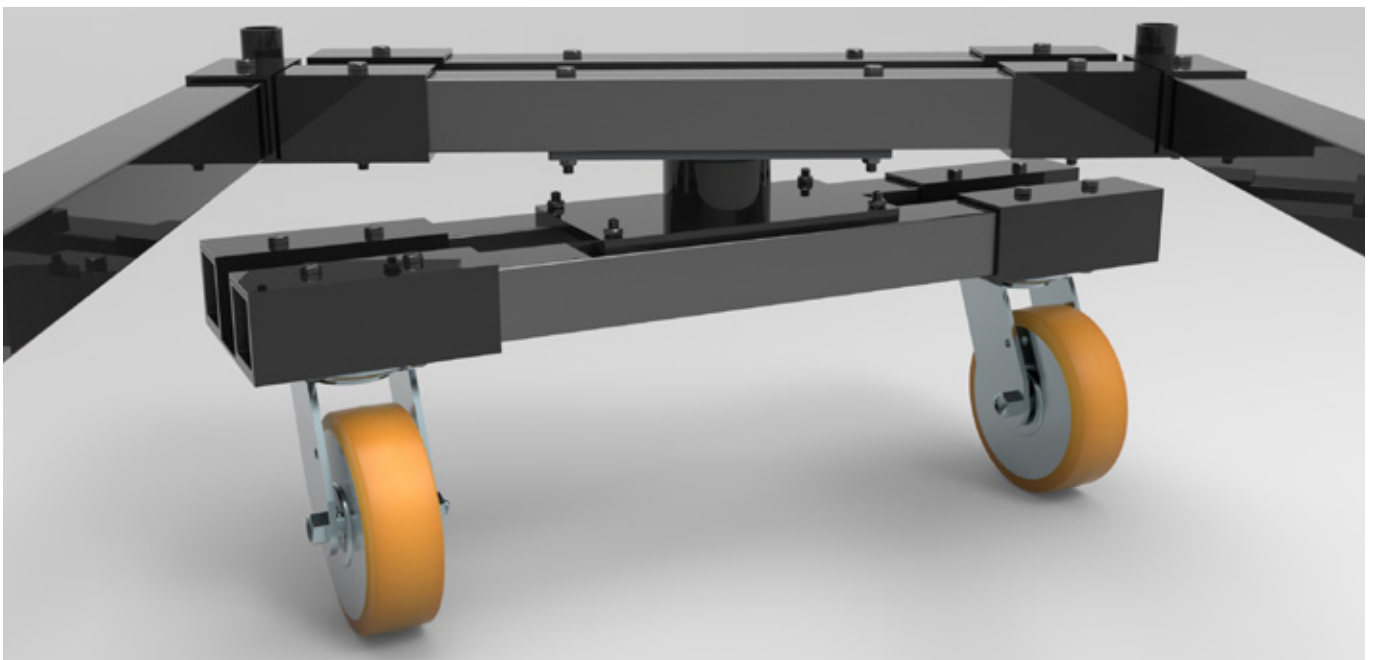

## TUBOS

### CÁLCULO DEL TAMAÑO DEL CORTE DE LOS TUBOS

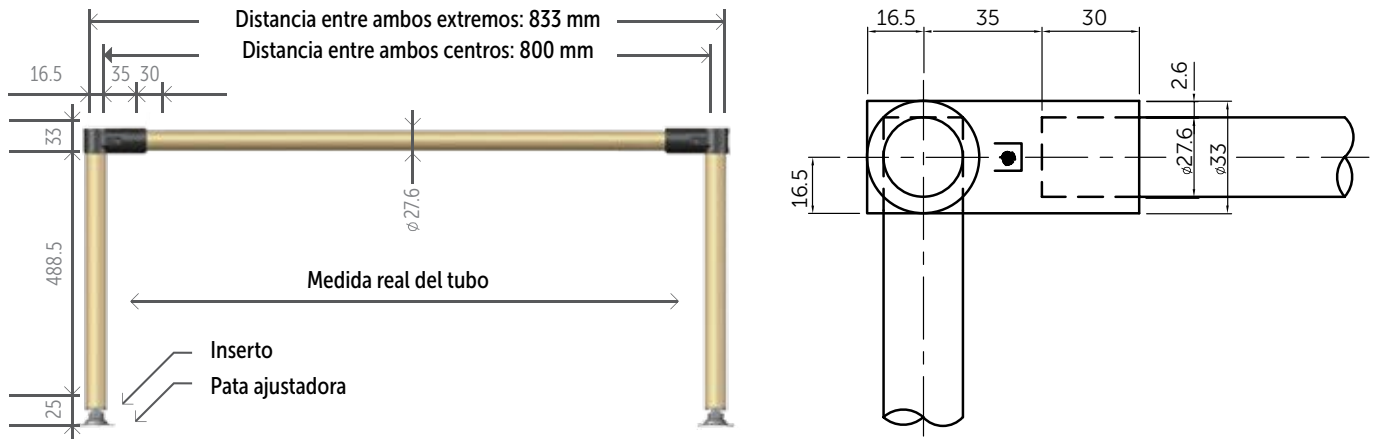

	<b>Cálculo de longitudes horizontales</b>	$\frac{800}{-70}$ <b>730 mm</b>	Distancia entre ambos centros Distancia total en exteriores del tubo y centros de uniones (35mm x 2) Medida sugerida del tubo para ser cortado
	<b>Cálculo de longitudes verticales</b>	$\frac{530}{-25}$ $\frac{+17}{522 \text{ mm}}$	Distancia entre ambos centros Distancia (espacio) entre el extremo del tubo y el extremo de la pata Distancia entre el centro y la superficie de la unión Medida sugerida del tubo para ser cortado

### LÍMITES DE TEMPERATURA

La temperatura de uso sugerida para los tubos con resina ABS y uniones de acero es de: -10° C a 80° C, evite exponer a temperaturas fuera de estos límites o cerca del fuego.

### UNIONES

Máxima fuerza de resistencia en los tubos atados con las uniones de metal.

### PRUEBA

Velocidad: 5 mm/min  
Temperatura: 23 °C

DIRECCIÓN	TUBO ABS	TUBO DE ACERO
X	75 KG	75 KG
Y	85 KG	85 KG

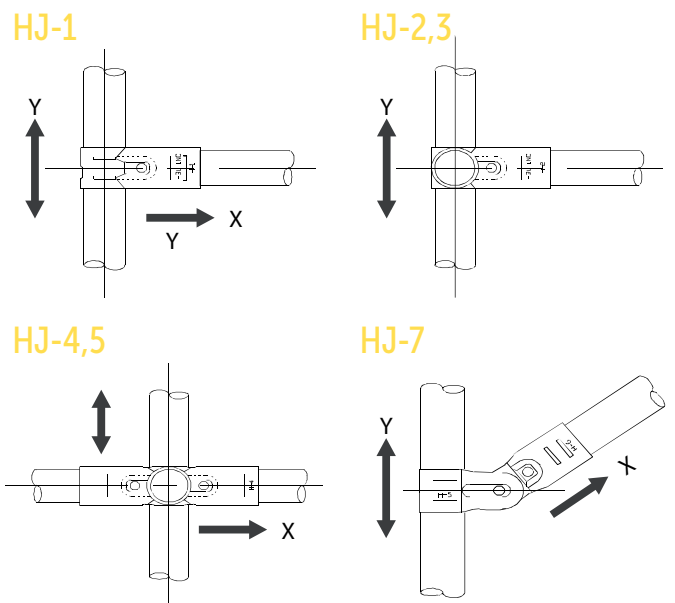



## CARGA MÁXIMA ADMISIBLE PARA TUBOS

### Condiciones de prueba

Velocidad de tensión: 5mm/min

Rango de Carga: 0~2,000kgf

Temperatura: 23 °C

Distancia entre apoyos: 450/1000/1500/1800 mm

Los datos fueron obtenidos en un ambiente controlado y pueden ser afectados por variaciones en el ambiente.



CÓDIGO	PRODUCTO	DISTANCIA ENTRE APOYOS			
		450 mm	1,000 mm	1,500 mm	1,800 mm
MP-1070	TUBO ABS STANDARD 0.7 mm	175.5	86.0	60.0	50.0
MP-1100	TUBO ABS STANDARD 1.0 mm	337.5	154.4	105.3	74.9
MP-1200	TUBO ABS STANDARD 2.0 mm	557.9	227.0	147.0	112.8
ST-1070 (SUS 201)	TUBO DE ACERO INOXIDABLE 0.7 mm	175.8	86.9	60.6	50.0
ST-1110 (SUS 201)	TUBO DE ACERO INOXIDABLE 1.1 mm	405.0	172.9	129.6	101.8
SL-1010	TUBO SLIDE 1.0 mm	377.1	162.9	109.2	83.2
AL-1102	TUBO DE ALUMINIO 1.1 mm	231.2	99.6	67.5	53.0

## CARGA MÁXIMA ADMISIBLE PARA ROLLERS

POR TRAMO DEL ROLLER	ROLLER (ancho)	Ø	LONGITUD	CAP. DE CARGA
Condiciones de prueba Velocidad: 5mm/min Temperatura: 23° C 	36 mm	26 Ø	1,000 mm	80 kgf
	40 mm	30 Ø		100 kgf
	60 mm	30 Ø		115 kgf
	60 mm	16 Ø		105 kgf
	73 mm	34 Ø		215 kgf
	73 mm	18 Ø		225 kgf
	85 mm	34 Ø		380 kgf

COMPRESIÓN DE ROLLER	ROLLER (ancho)	Ø	CAP. DE CARGA
Condiciones de prueba Temperatura: 23° C 	36 mm	26 Ø	140 kgf
	40 mm	30 Ø	170 kgf
	60 mm	30 Ø	240 kgf
	60 mm	16 Ø	145 kgf
	73 mm	34 Ø	520 kgf
	73 mm	18 Ø	165 kgf
	85 mm	34 Ø	580 kgf

## DESPIECE DE MATERIALES

Las siguientes figuras muestran el ensamble real de una Solución Lean MDC y sus componentes.

### CARRO 2 NIVELES

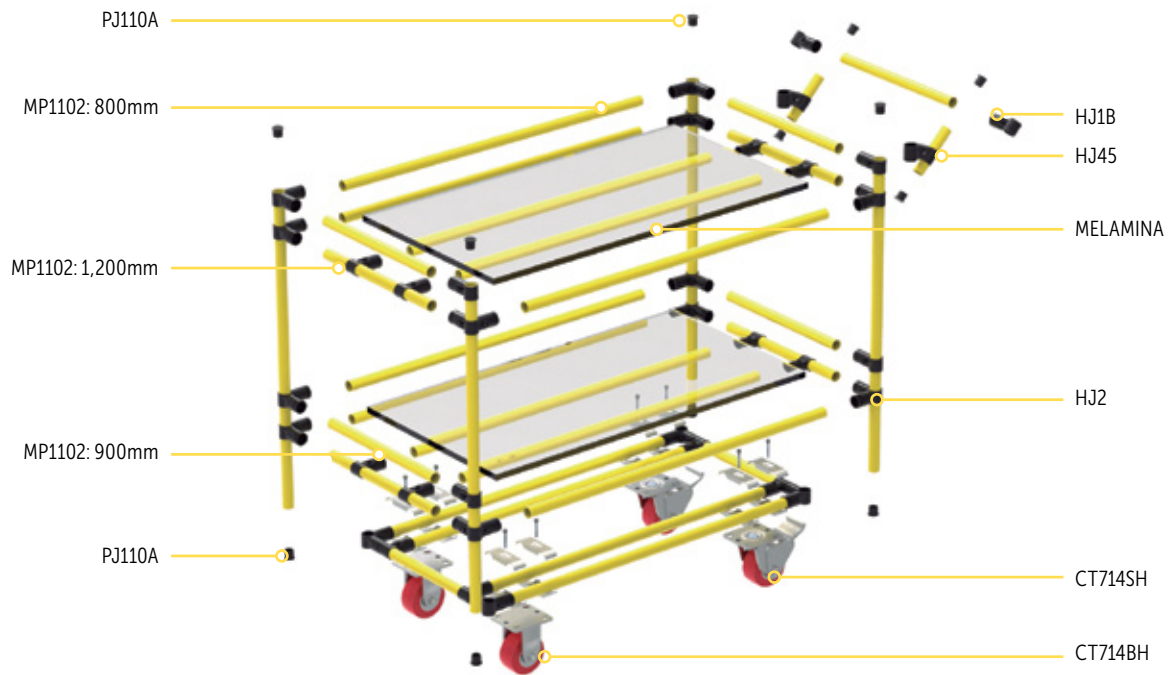

### FLOW RACK

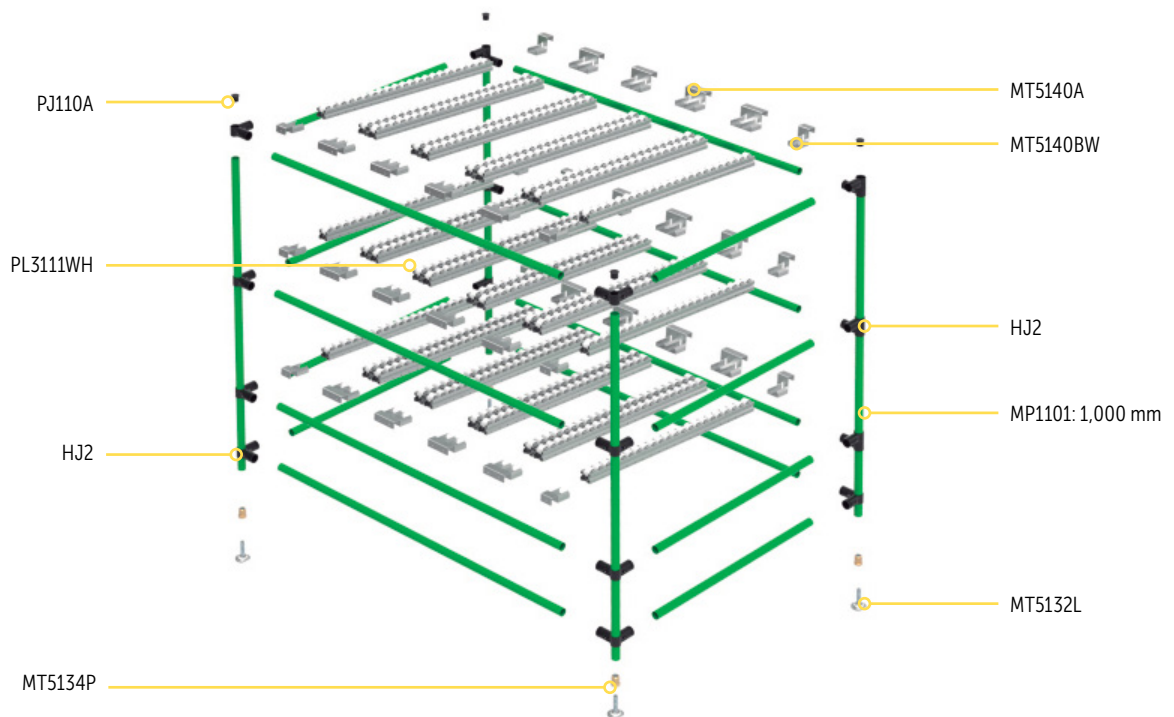

# APLICACIONES





# APLICACIONES

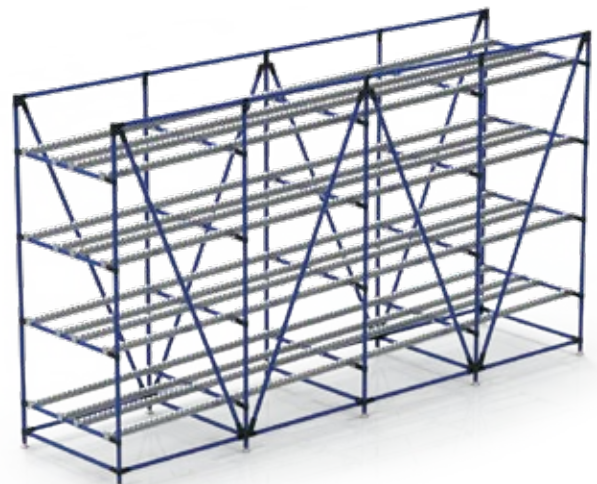



# CONTENIDO

SOLUCIONES LEAN MDC	2
TUBOS	6
UNIONES METÁLICAS	8
MÉTODOS DE UNIÓN	10
pe SQR	13
UNIONES SQR	15
MÉTODOS DE UNIÓN SQR	16
ACCESORIOS DE PLÁSTICO	17
ACCESORIOS METÁLICOS	19
SUPERFICIES	24
PATAS Y AJUSTADORES	25
INSERTOS Y CUBIERTAS PARA TUBO	26
MICAS PROTECTORAS	27
TORNILLERÍA	28
ROLLERS	29
ÁNGULOS y GUÍAS	36
RODAMIENTOS	38
GAVETAS	42
CONTENEDORES	43
CARRO Z	47
INFORMACIÓN TÉCNICA	48
GALERÍA	51



DISTRIBUIDOR AUTORIZADO  
DEL SISTEMA LEAN MDC®

Este catálogo fue impreso en el mes de julio de 2022.  
Todos los derechos reservados®  
Lean MDC, S. de R.L. de C.V.



📍 Pasteur 1313-A  
Col. Tecnológico  
C.P.25716  
Monclova, Coahuila

☎ Tel. 866 648 27 27

📞 Cel. 866 115 91 72

✉ [ventas@siamsacv.com](mailto:ventas@siamsacv.com)

🌐 [www.siamsacv.com](http://www.siamsacv.com)